

# HIERARCHICAL MODEL COMPOSITION

Lucian Smith  
University of Washington &  
California Institute of Technology



# CORE SBML MODELS

## Biological Content:

Reactions

Species

Parameters

Compartments

Functions

Events

Math

# HIERARCHICAL MODEL COMPOSITION MODELS ('COMP')

## Biological Content:

Reactions

Species

Parameters

Compartments

Functions

Events

Math

# HIERARCHICAL MODEL COMPOSITION MODELS ('COMP')

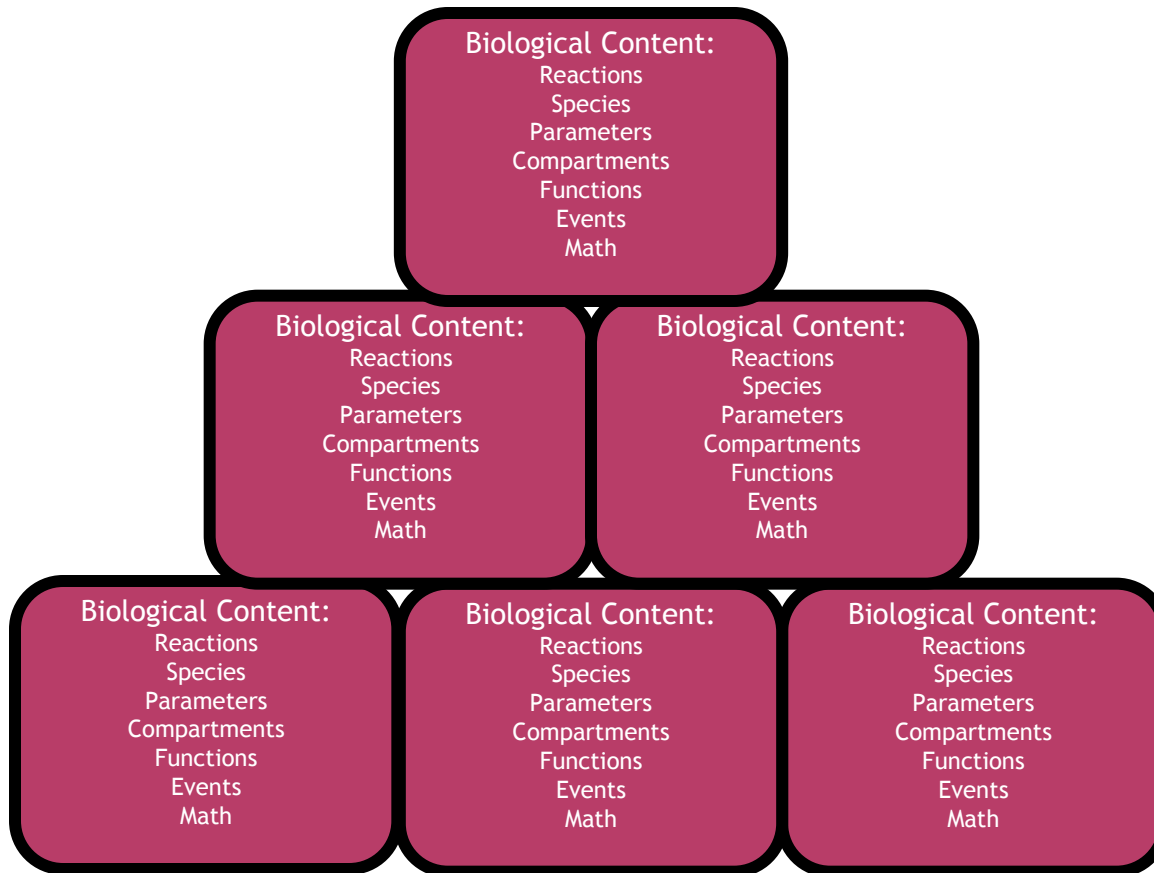

# THREE BASIC TASKS:

- Define multiple models
- Import copies as submodels
- Connect their elements

# 1 DEFINE MULTIPLE MODELS



The diagram consists of a large, rounded rectangular container with a light purple gradient and a black border. Inside this container, the word 'Model' is written in white, centered. Below the 'Model' text, the word 'Document' is written in black, also centered. The container has a slight 3D effect with a darker purple shadow at the bottom.

Model

Document

# 1 DEFINE MULTIPLE MODELS

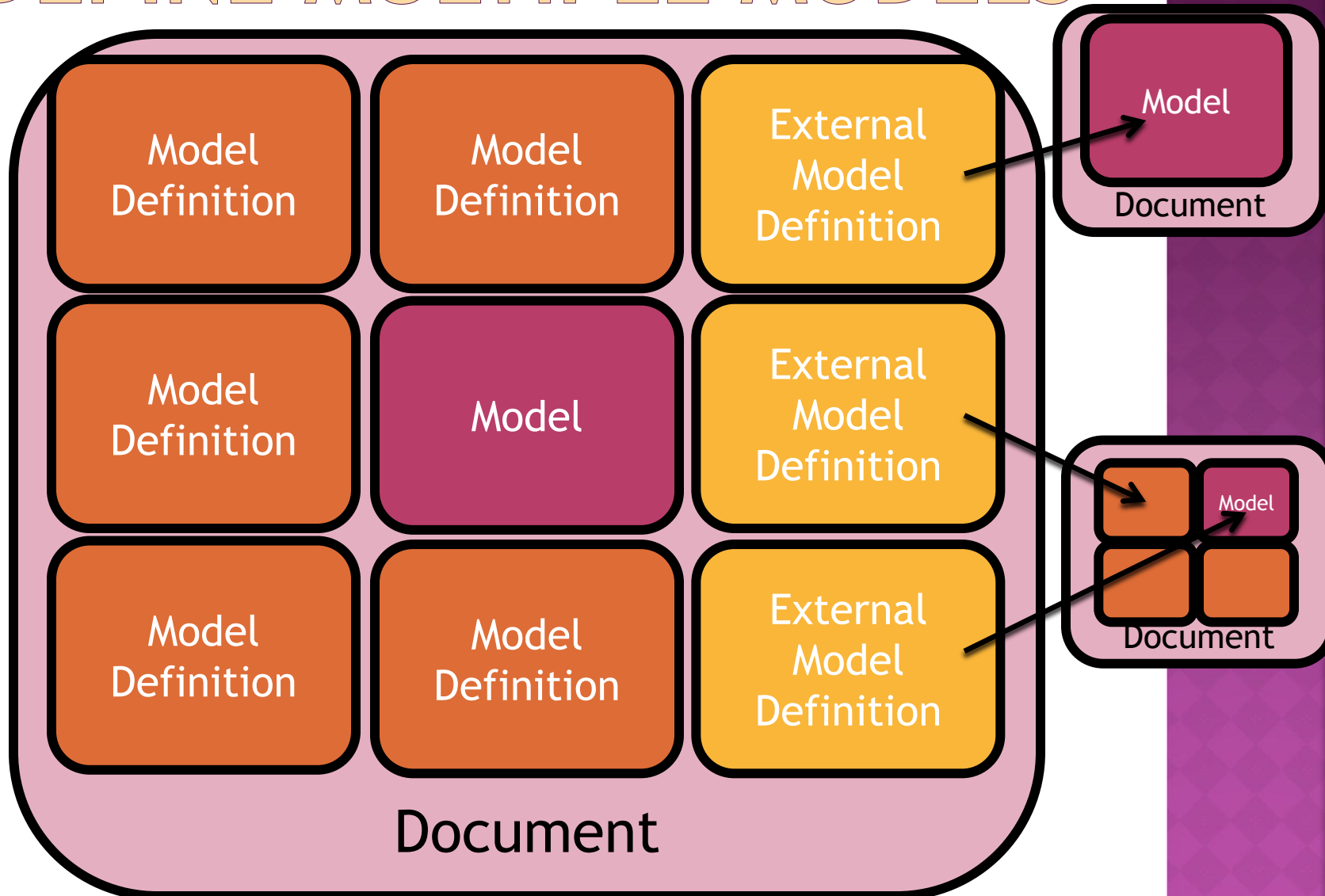

# 2 IMPORT COPIES AS SUBMODELS

Nature Precearings . doi: 10.1038/npre.2011.16402.1.1 Posted 13 Sep 2011

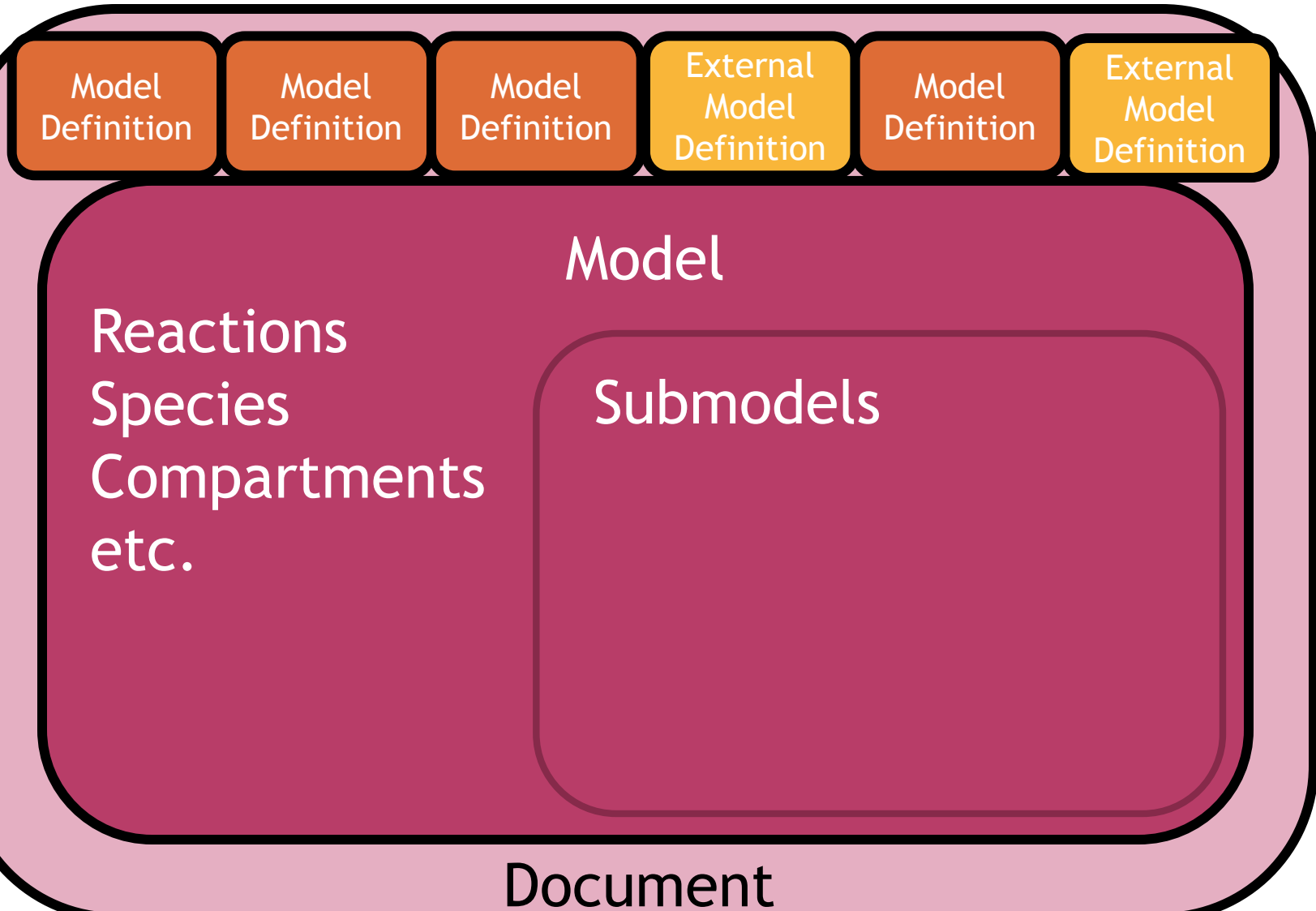

Document



# 2 IMPORT COPIES AS SUBMODELS

Nature Precearings . doi:10.1038/npre.2011.0402.1.1 Posted 13 Sep 2011

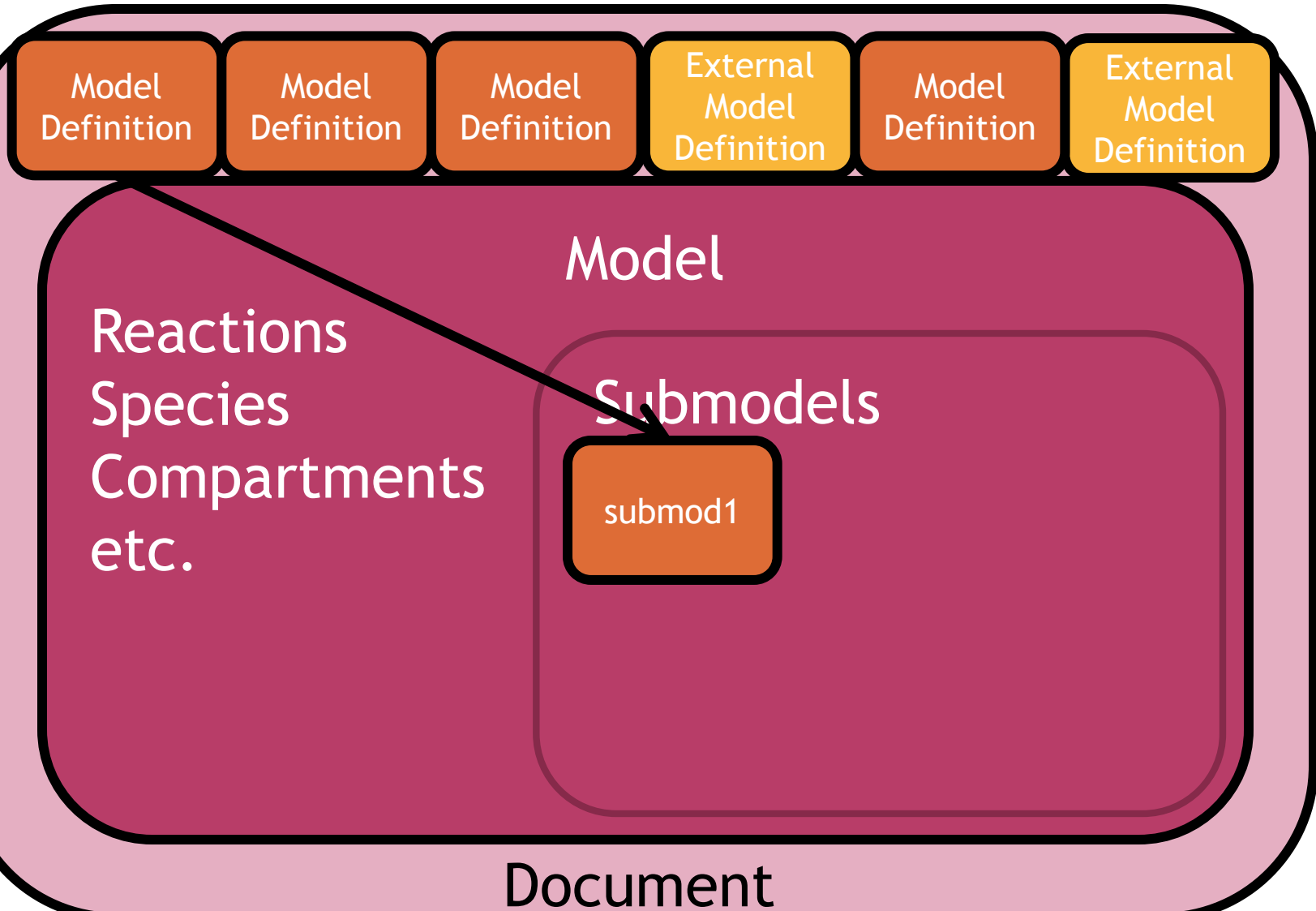

# 2 IMPORT COPIES AS SUBMODELS

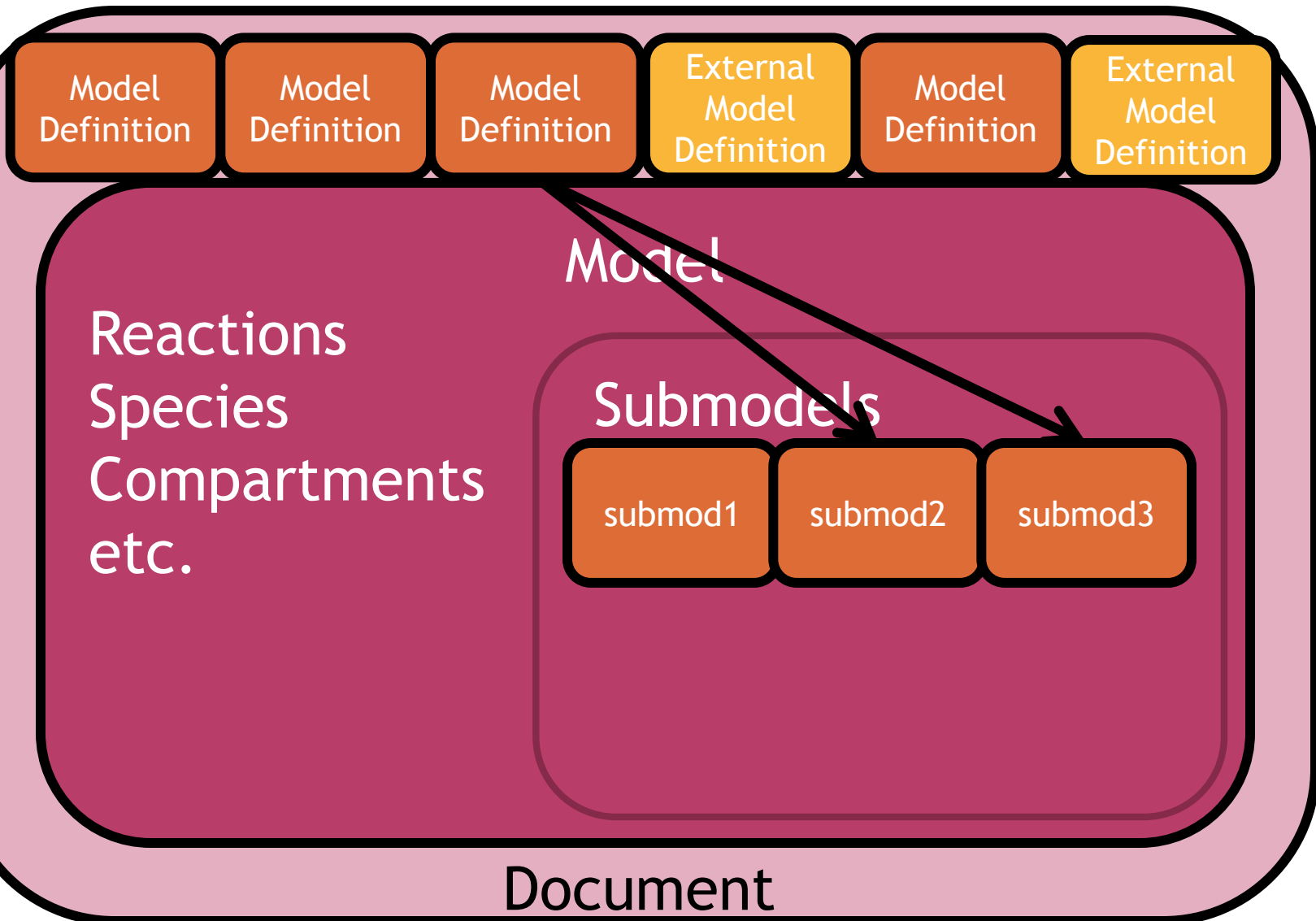

# 2 IMPORT COPIES AS SUBMODELS

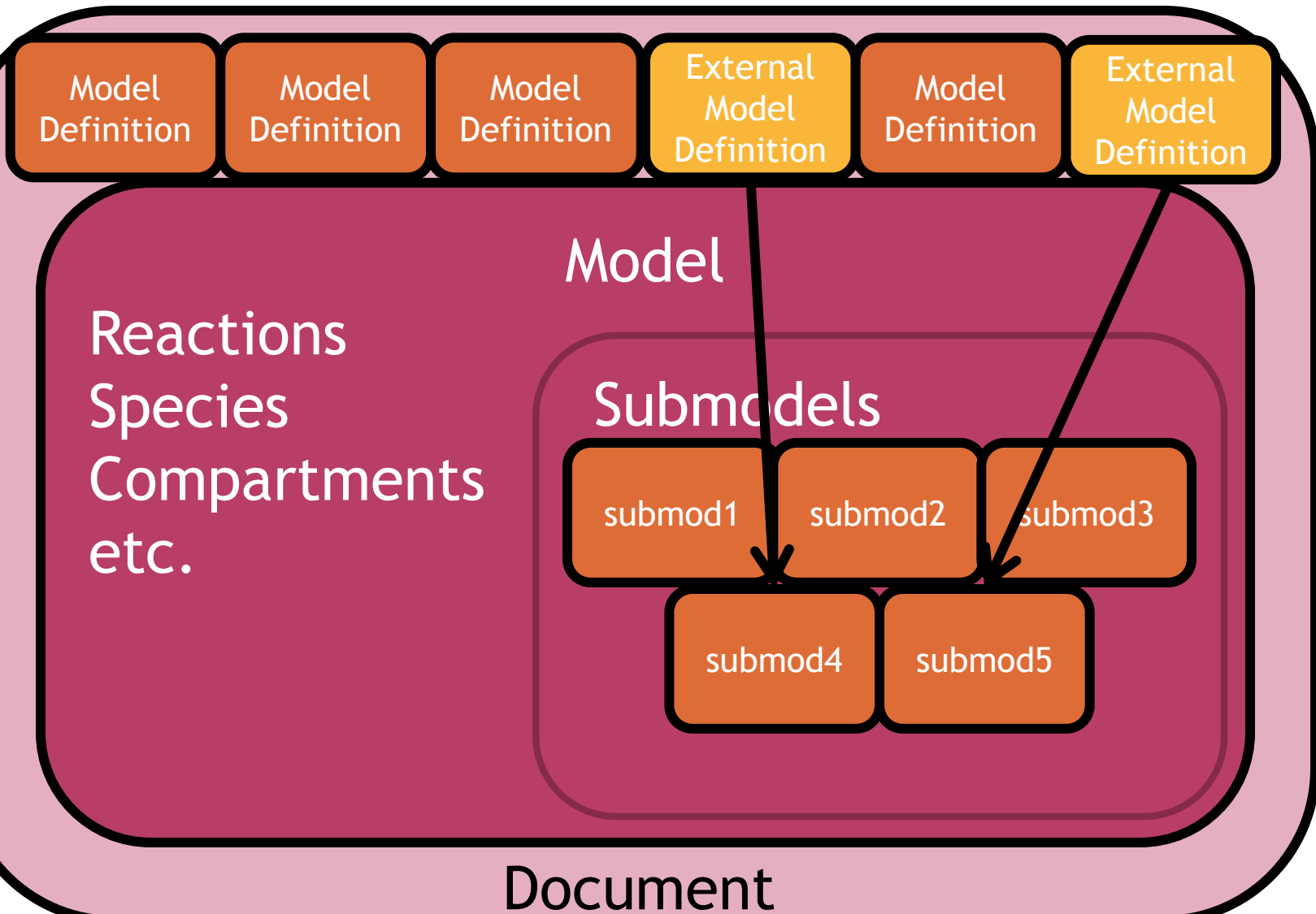

# 2 IMPORT COPIES AS SUBMODELS

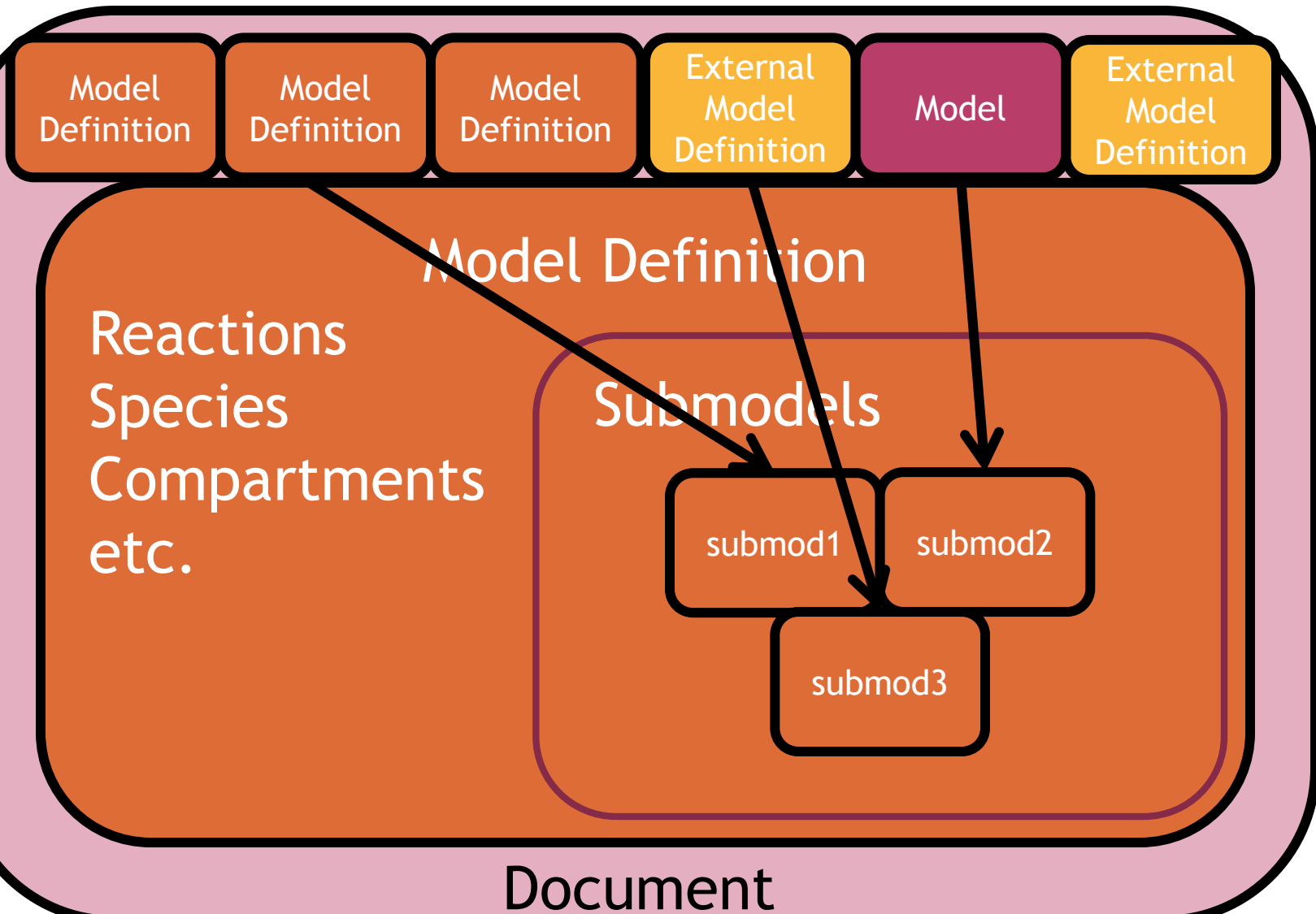

# 2 IMPORT COPIES AS SUBMODELS

Reactions  
Species  
Compartments  
etc.

Model

Submodels

submod1: Reactions, Species,  
Compartments...

submod2: Species, Events

submod3: Reactions, Species,  
Events

# 3 CONNECT THEIR ELEMENTS



# 3 CONNECT THEIR ELEMENTS

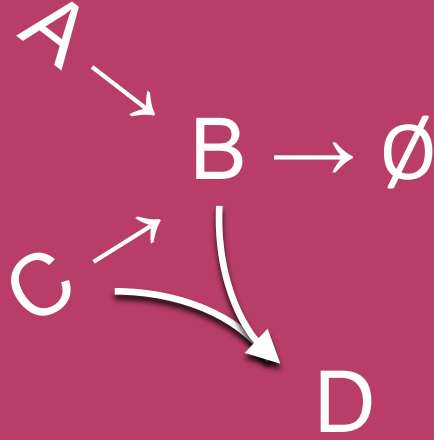

# COMPLICATION 1: DELETIONS

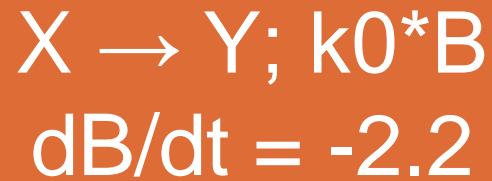



# COMPLICATION 1: DELETIONS

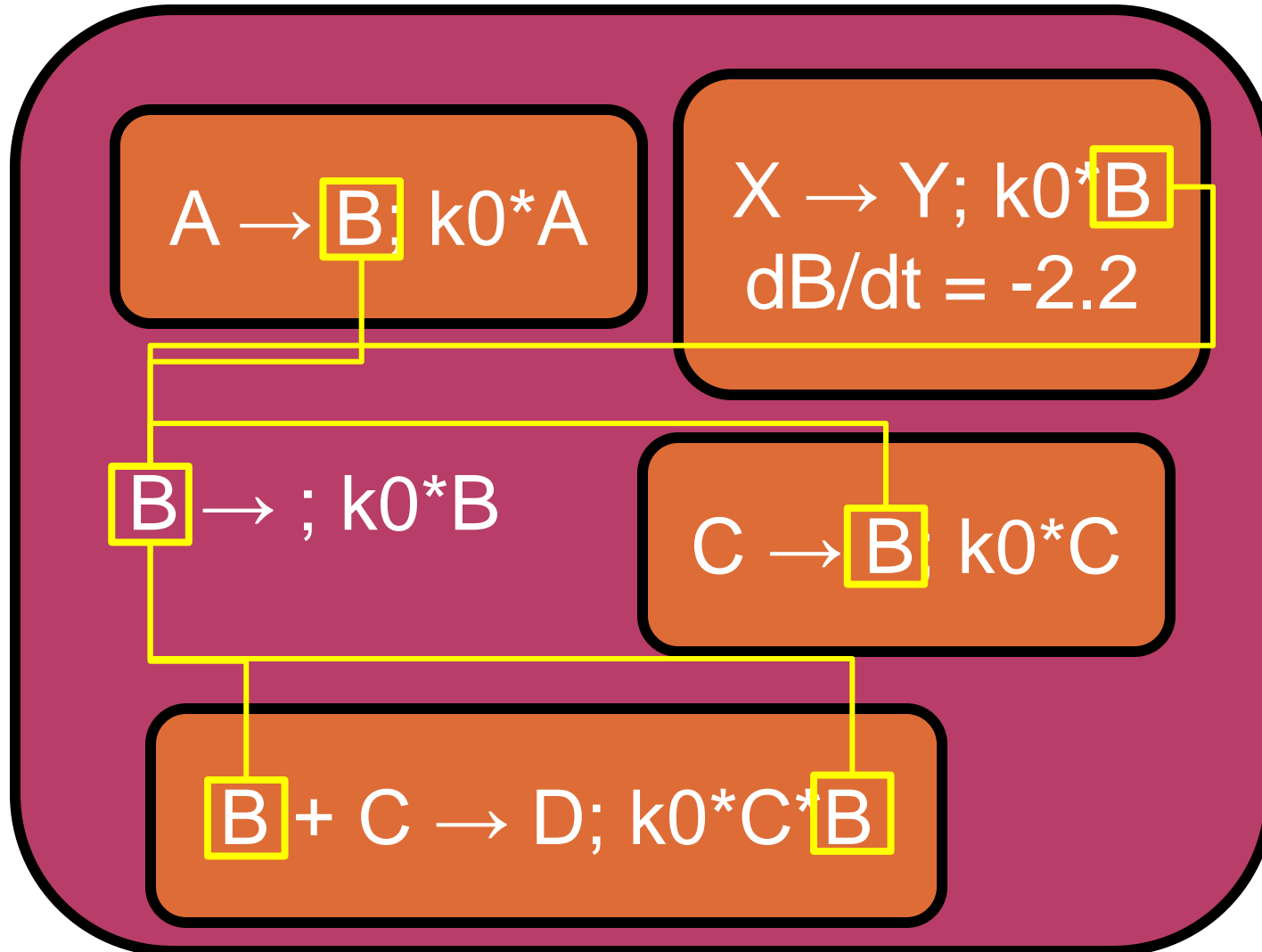

# COMPLICATION 1: DELETIONS

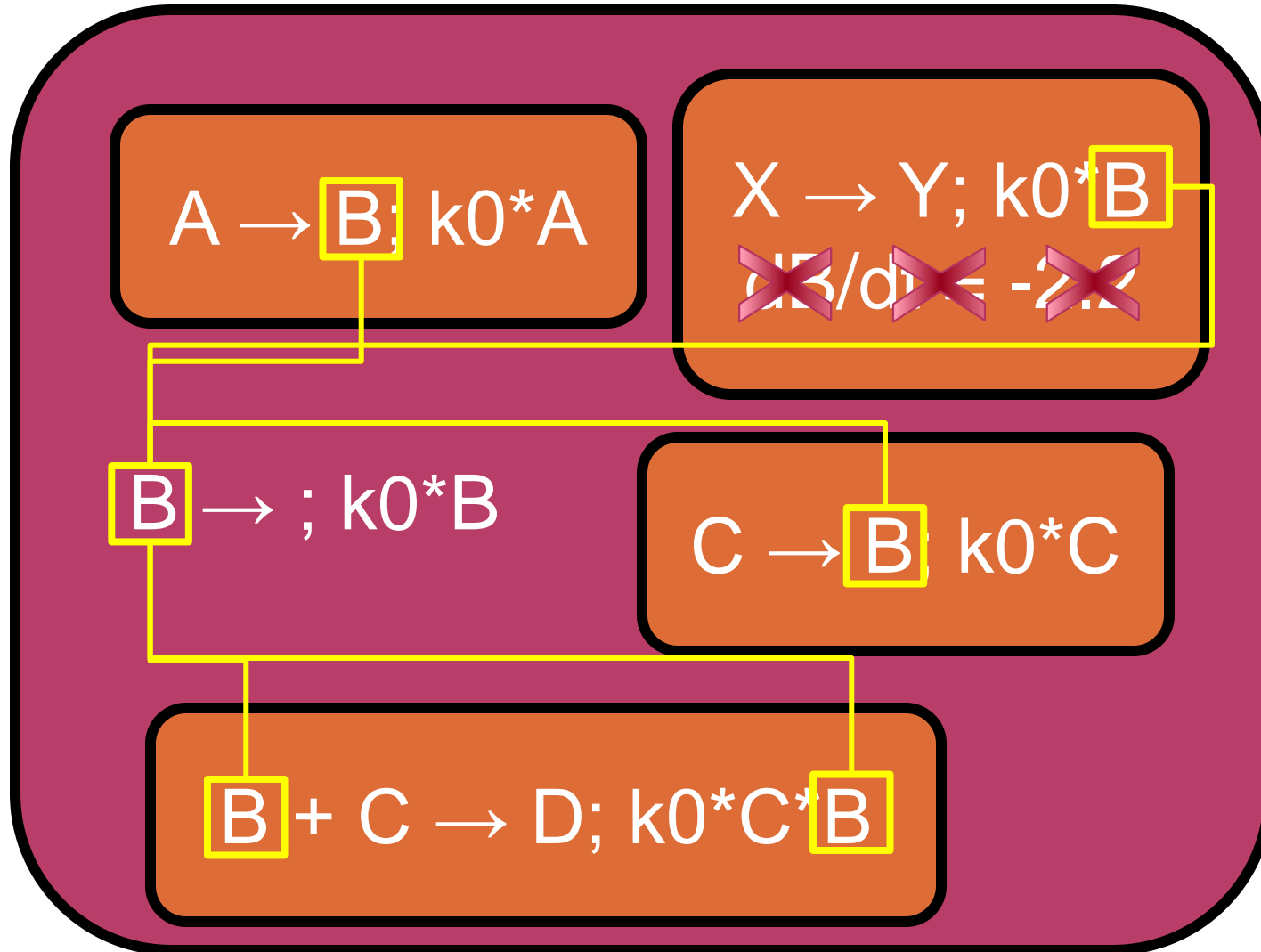

# COMPLICATION 2: CONVERSION FACTORS

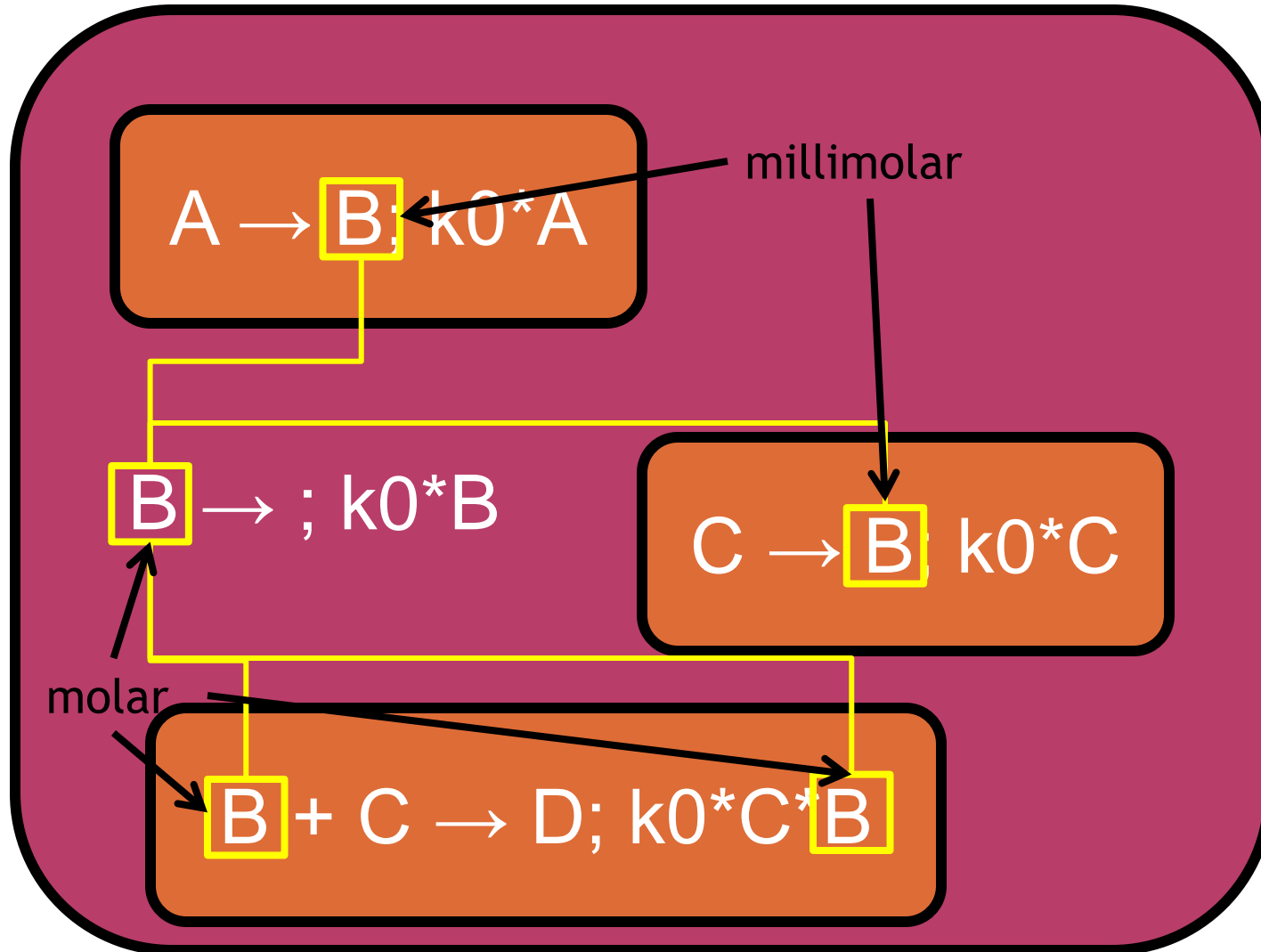

# COMPLICATION 2: CONVERSION FACTORS

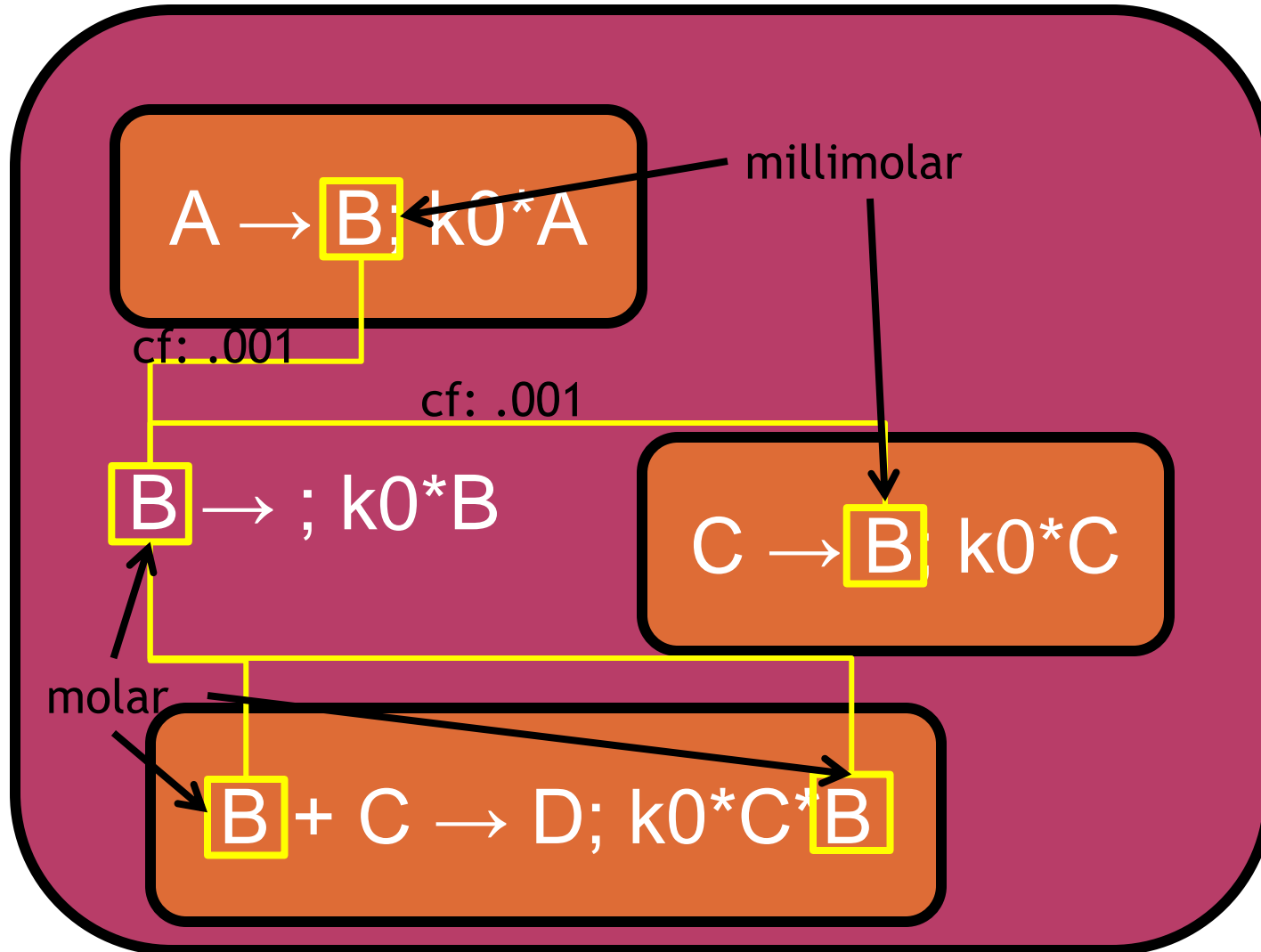

# COMPLICATION 3: PORTS

Nature Preceings . doi:10.1038/npre.2011.0402.1.1 Posted 13 Sep 2011

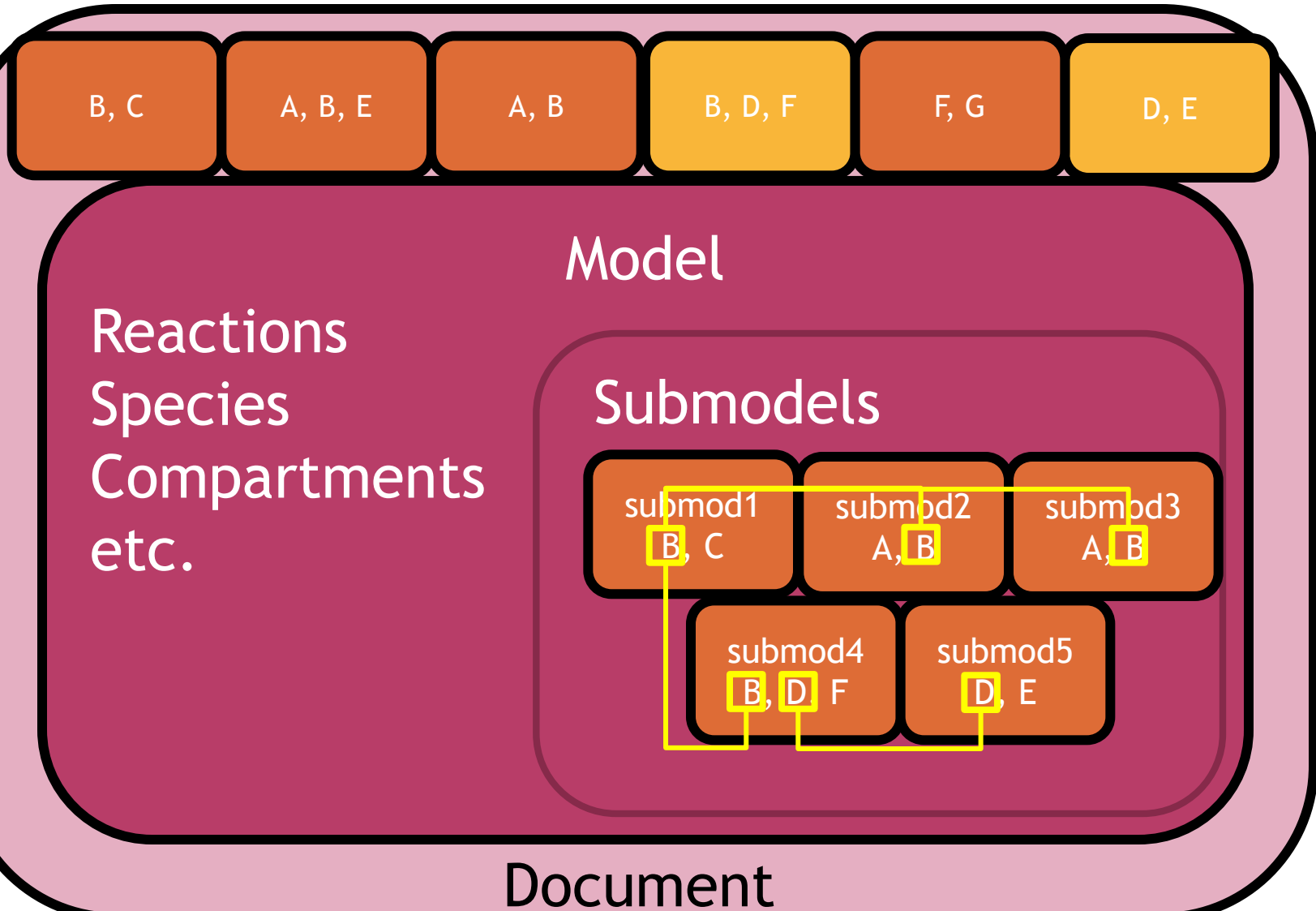

Document

# PART II: XML STRUCTURES



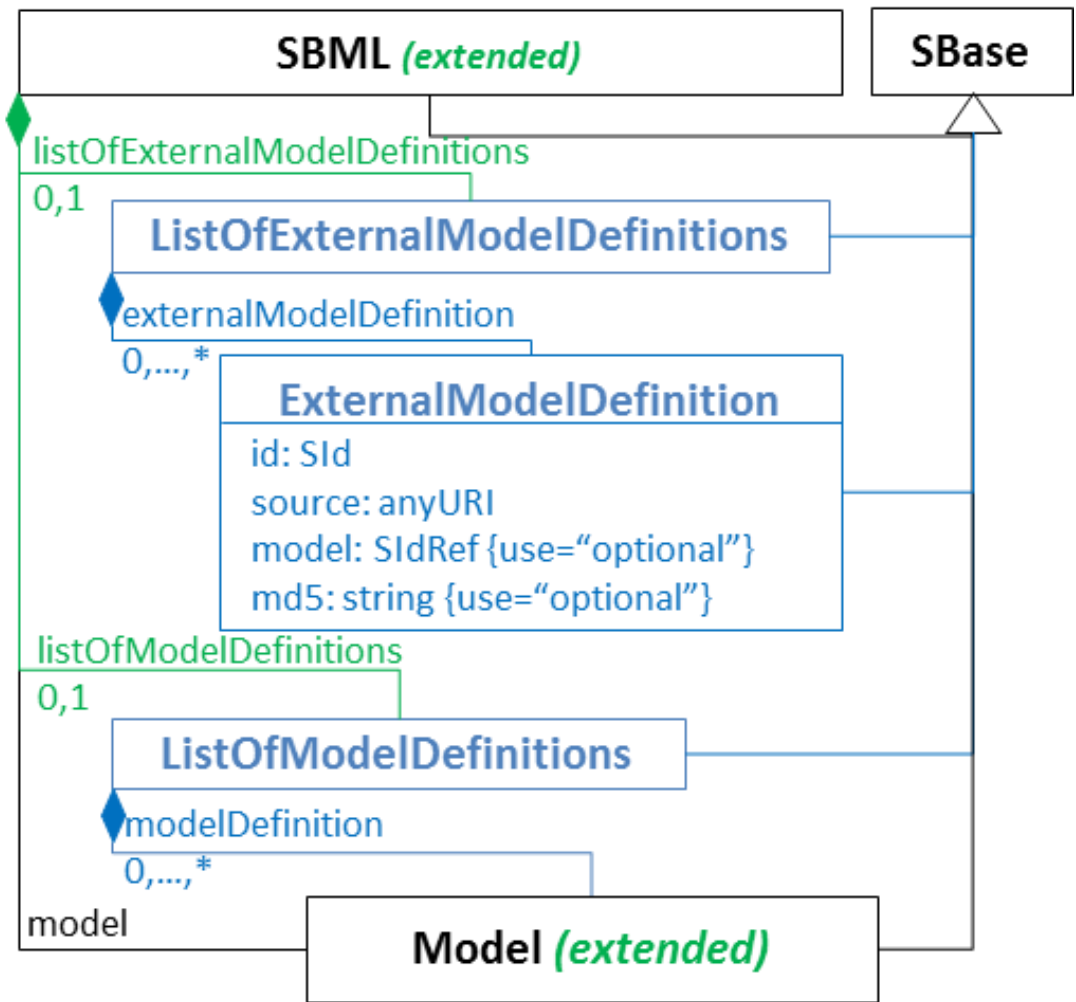
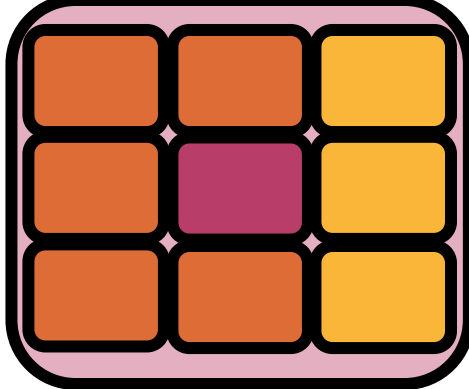

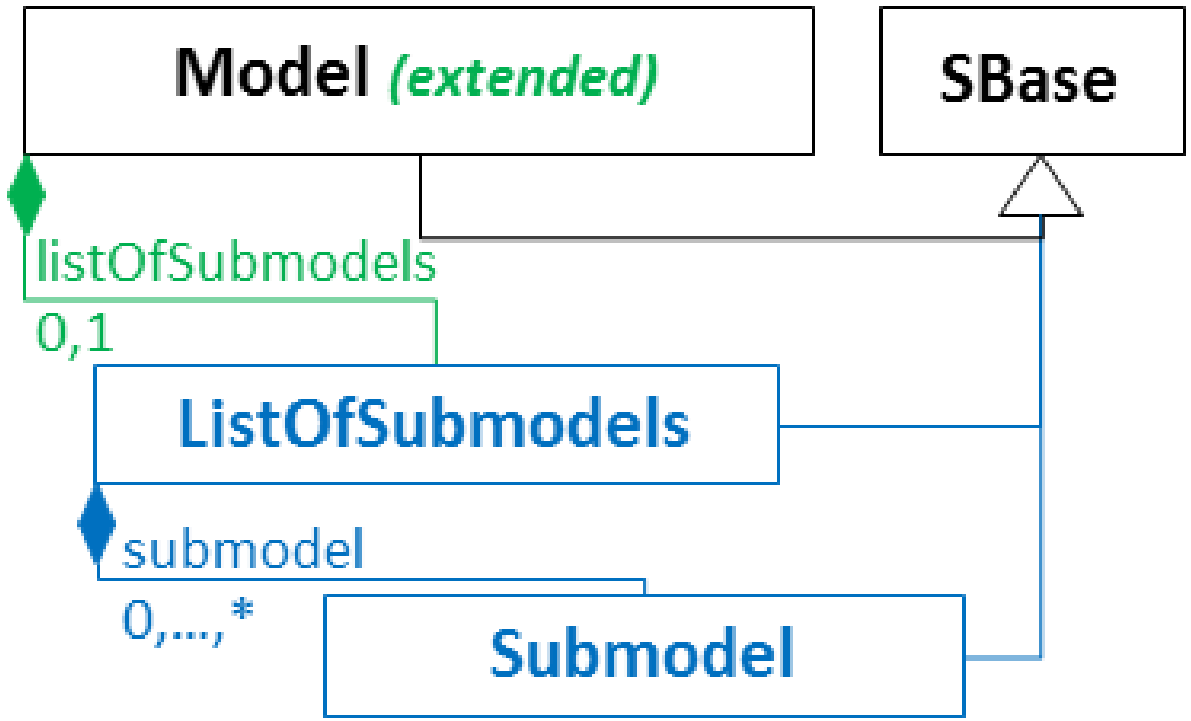
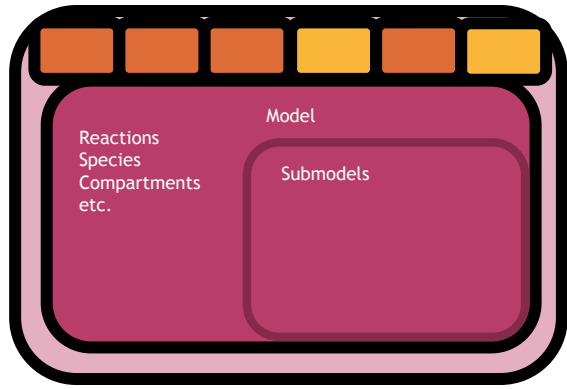



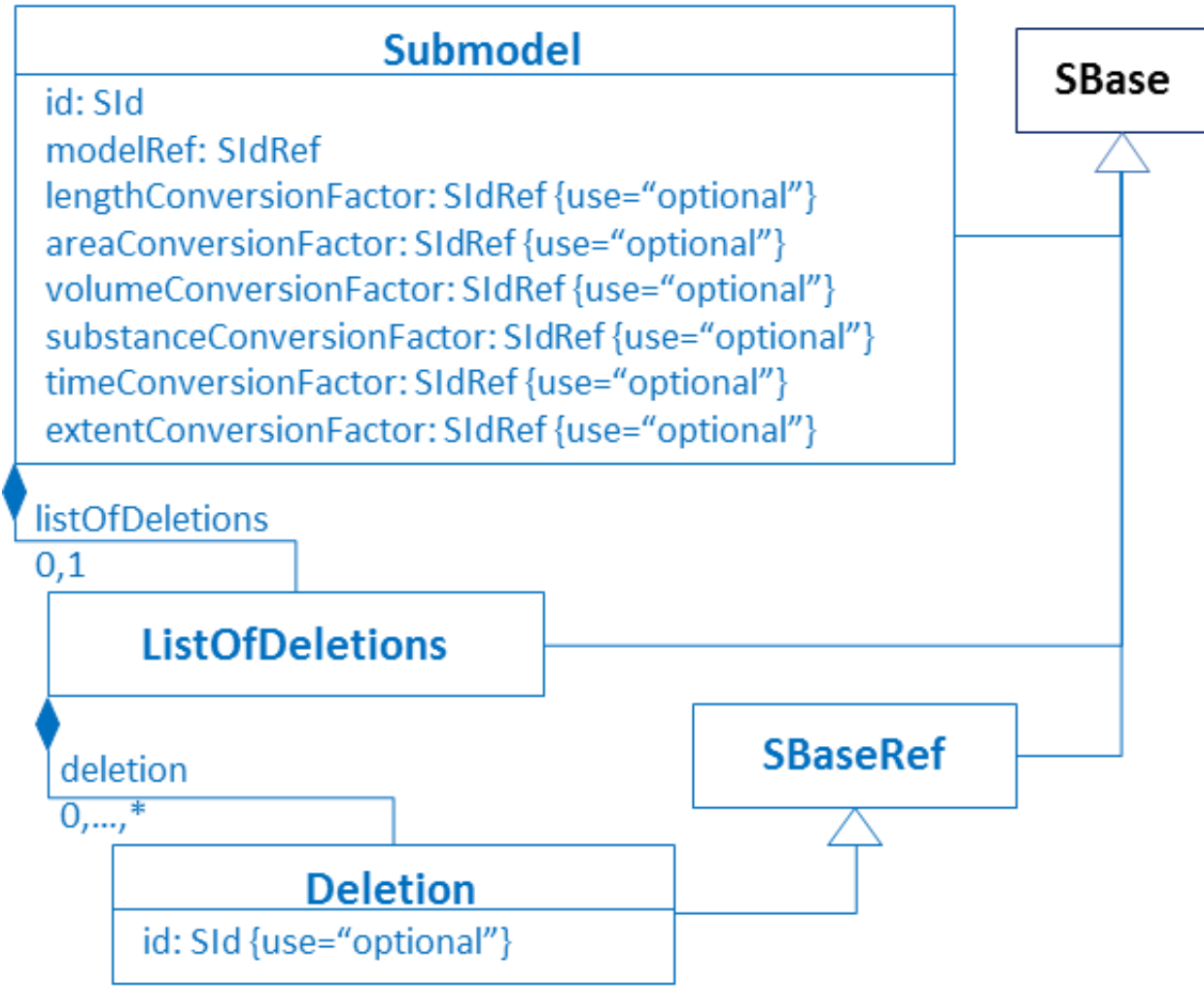
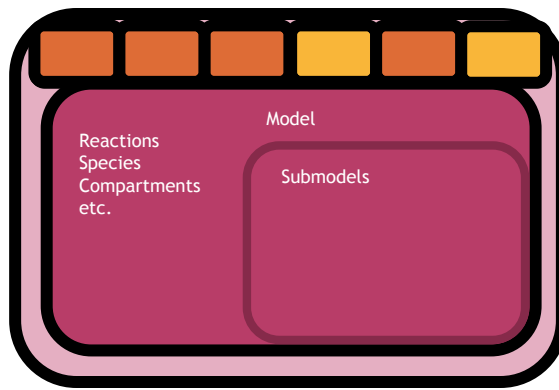

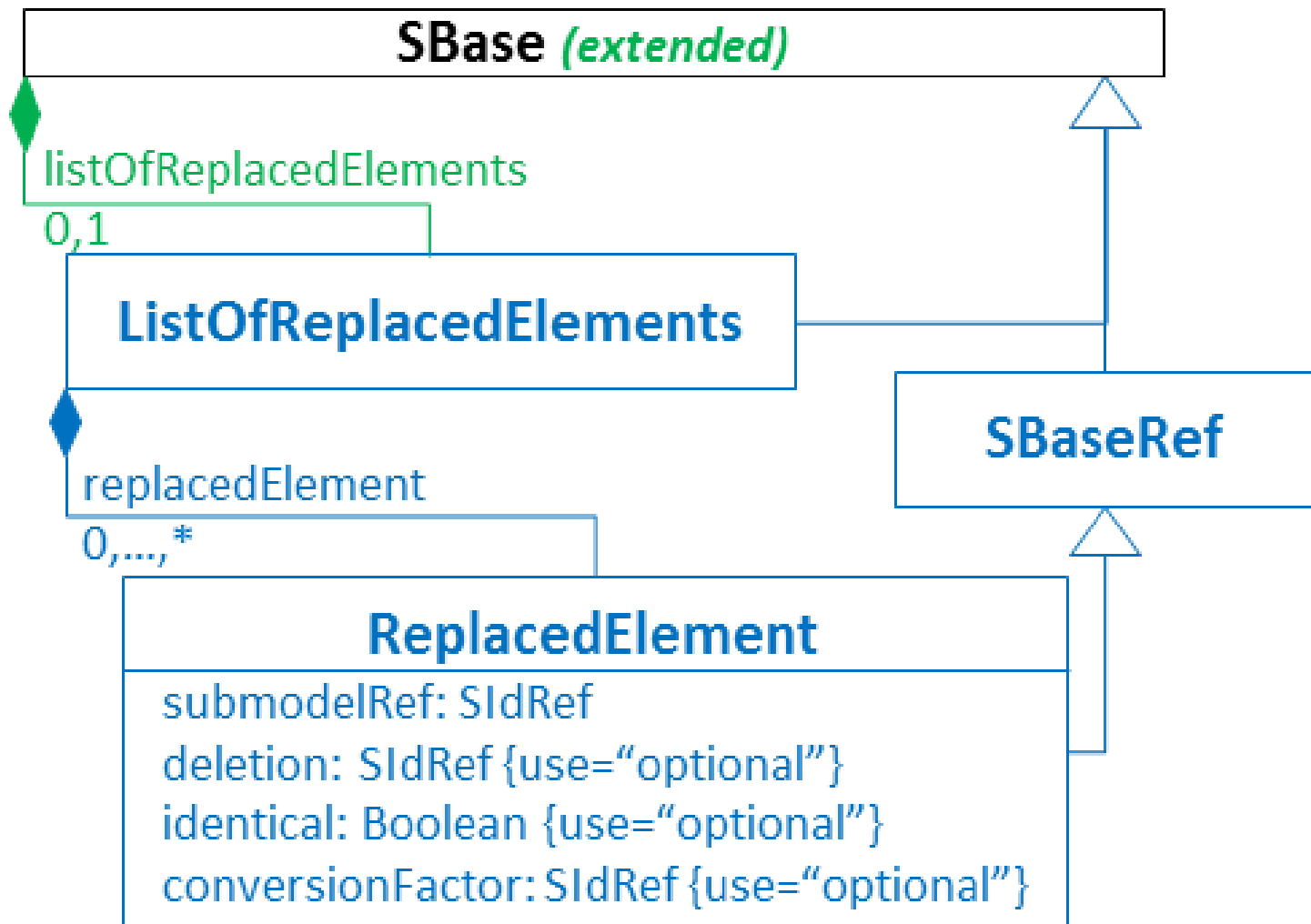
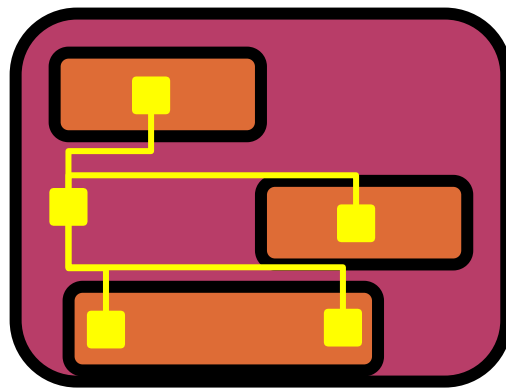

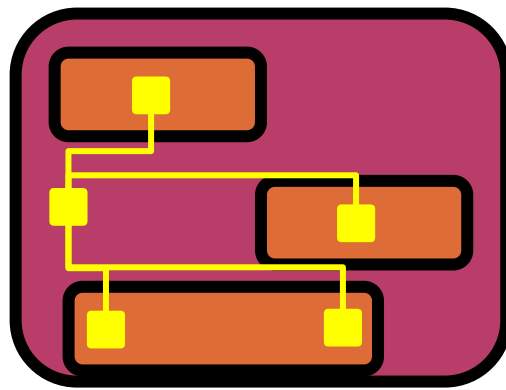

## SBaseRef

port: PortSIdRef {use="optional"}  
idRef: SIdRef {use="optional"}  
unitRef: UnitSIdRef {use="optional"}  
metaIdRef: IDREF {use="optional"}

sbaseRef

0,1

## SBase



# POTENTIAL ISSUE: CONVERSION FACTORS



Component	Attribute value	Automatic conversion factor
AlgebraicRule	(All)	1
AssignmentRule	(All)	Conversion factor for referenced object
Compartment	spatialDimensions="1"	lengthConversionFactor
Compartment	spatialDimensions="2"	areaConversionFactor
Compartment	spatialDimensions="3"	volumeConversionFactor
Compartment	spatialDimensions not equal to "1", "2", or "3"	1
Constraint	(All)	(None needed)
Delay	(All)	timeConversionFactor
EventAssignment	(All)	Conversion factor for referenced object
FunctionDefinition	(All)	1
InitialAssignment	(All)	Conversion factor for referenced object
KineticLaw	(All)	$\frac{\text{extentConversionFactor}}{\text{timeConversionFactor}}$
Implied rate of change of a species	(All)	$\frac{\text{substanceConversionFactor}}{\text{timeConversionFactor}}$
Parameter	(All)	1
Priority	(All)	1
RateRule	(All)	$\frac{\text{Conversion factor for referenced object}}{\text{timeConversionFactor}}$
Species	hasOnlySubstanceUnits="true"	substanceConversionFactor
Species	hasOnlySubstanceUnits="false"	$\frac{\text{substanceConversionFactor}}{\text{Conversion factor for referenced object}}$
Species	hasOnlySubstanceUnits="true" replaced by a Species having hasOnlySubstanceUnits="false"	$\frac{\text{substanceConversionFactor}}{\text{Compartment size}}$
Species	hasOnlySubstanceUnits="false" replaced by a Species having hasOnlySubstanceUnits="true"	$\frac{\text{substanceConversionFactor} \cdot (\text{Compartment size})}{\text{Conversion factor for compartment}}$
SpeciesReference	(All)	1
Trigger	(All)	(None needed)
(Unknown)	(All)	1

Table 3: Conversion factors used for the different components defined by SBML Level 3 Core.

# POTENTIAL ISSUE: CONVERSION FACTORS

- ⦿ Perhaps remove conversion factors for submodels?
- ⦿ Retain conversion factors for replacements
- ⦿ Parameters unconverted anyway...

# PART III: EXISTING IMPLEMENTATIONS



# LIBSBML-COMP

- All classes implemented
- Get/set all attributes
- Add/remove all children
- Requires libSBML 5.1.0
- `libsbml/5.1-packages-beta/comp-5.1.0-beta-1.zip`
  
- In-progress: convenience functions
  - Flattening
  - Submodel instantiation



# ANTIMONY

- Read/write hierarchical models!
- In-progress:
  - Replace rules more robustly
  - Introduce deletions
- Can only ‘replace’ elements with ids.

# ACKNOWLEDGEMENTS

Contributor	Affiliation	City and Country
Stefan Hoops	Virginia Bioinformatics Institute	Blacksburg, Virginia, US
Nicolas Le Novère	EMBL-European Bioinformatics Institute	Hinxton, Cambridge, UK
Andrew Finney	(Independent)	Oxford, UK
Martin Ginkel	Max Planck Institute for Dynamics of Complex Technical Systems	Magdeburg, DE
Wolfram Leibermeister	Max Planck Institute for Molecular Genetics	Berlin, DE
Ranjit Randhawa	Dept. of Computer Science, Virginia Tech.	Blacksburg, VA, US
Jonathan Webb	BBN Technologies	Cambridge, MA, US

*Table 1: List of individuals who made significant contributions to the development of prior SBML proposals that influenced the present version of hierarchical model composition.*

⦿ ...and members of sbml-discuss  
and sbml-comp