

Purification of Secretin by Freezing Out of Impurities from Methanolic Solution at -80°C .

WE recently described a method for the purification of secretin, based on the repeated isoelectric precipitation of impurities from solutions of crude secretin in methanol¹. The final, lyophilized product had an activity varying, in different preparations, from 600 to 900 cat units¹ per mgm. ash-free substance.

We have found that a further twofold increase in activity may be achieved by dissolving the purified substance to a 1 per cent solution in absolute methanol, adjusting the pH to 7.0 and allowing to stand at -80°C . for a couple of days. An ash-free fraction, comprising about nine-tenths of the protein matter originally present in solution, and including about seven-tenths of the secretin activity, is precipitated. After removal of this precipitate, the purified product is precipitated from the solution with several volumes of water-free ethyl ether.

The product comprises about one-tenth of the protein matter originally in solution, and contains from two- to three-tenths of the secretin activity, as well as practically all the ash. Its activity is about 1,500 cat units per mgm. ash-free substance.

In a few cases we have removed the ash by means of the ion-exchange resins 'Dowex 50' and 'Dowex 2' before dissolving the secretin in absolute methanol. In one case this led to a final product with the activity expected for an ash-free preparation, that is, 1,500 units per mgm. In the remaining cases, however, a considerable loss in activity occurred during treatment of the secretin with the resins.

J. E. JORPES
V. MUTT

Chemistry Department II,
Karolinska Institutet,
Stockholm,
March 2.

¹ Jorpes, J. E., and Mutt, V., *Biochem. J.*, **52**, 328 (1952).

A Micro Lipid Extractor

IN the course of studies of the phospho-compounds of bacteria, an apparatus was designed to make possible the quantitative extraction of phospholipid by the method of Reichert¹ on a micro scale. I have been prompted to give a brief description of this apparatus by other research workers in this laboratory who have found it useful².

The method of Reichert consists in heating the material to be extracted with methanol, evaporating to dryness and extracting the lipid with dry ether in a Soxhlet apparatus. The lower limit to the amount of material which can be handled by this method is set by the losses which accompany the transfer to and from the extraction thimble. The amount which could be handled was reduced to a level determined by the gravimetric error by eliminating the necessity for transfer. Both the preliminary treatment with methanol and the ether extraction were carried out in B 14 'Quickfit' tubes into which samples were initially weighed. The diagram shows the method of ether extraction, the rate of flow of ether being regulated at about 2 ml. per minute.

The determinations of total lipid contents of a large number of bacteria and bacterial fractions³

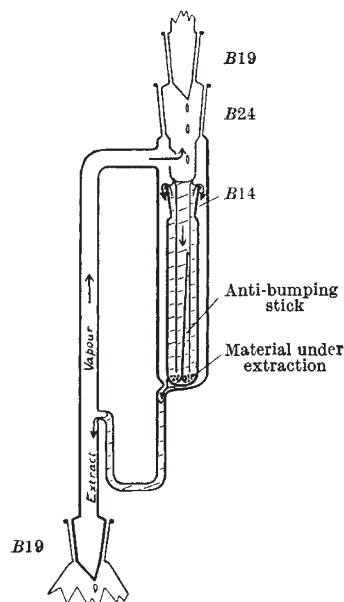

have been found to be reproducible to within the limit of the gravimetric error using 5–50 mgm. of material containing 0.3–5 mgm. of lipid and weighing with an air-damped aperiodic balance reading to 10 μgm .

PETER MITCHELL

Department of Biochemistry,
Tennis Court Road,
Cambridge. March 2.

¹ Reichert, R., *Helv. Chim. Acta*, **27**, 961 (1944).

² Northcote, D. H., and Horne, R. W., *Biochem. J.*, **52**, 232 (1952).
Perry, S. V., *Biochim. Biophys. Acta*, **8**, 499 (1952).

³ Mitchell, P., and Moyle, J., *J. Gen. Microbiol.*, **5**, 981 (1951); and in preparation.

Toxicity Studies on Silicone Rubber and Other Substances

TISSUES which are grown in a culture medium or perfused must not be brought into contact, directly or indirectly, with material which is toxic, and it is preferable if apparatus in use can be sterilized by dry heat. Vulcanized rubber tubing, lubricant greases, and paraffin-lined tubes which are at present used in this work have disadvantages.

Vulcanized rubber tubing is toxic because of its content of sulphur and talc. It requires special treatment before use, does not withstand the usual temperature of a dry heat oven, and must therefore be sterilized by some other means. Lubricant greases which might be used have too low a melting point for sterilization *in situ* on a ground-glass joint. Paraffin-lined tubes are satisfactory for storing plasma but require constant re-coating as they can only be used once.

It was thought that by replacing the above with silicone compounds there would be a considerable reduction in the amount of routine laboratory work. These compounds are relatively inert, chemically and physically, and if, in addition, they could be proved to be non-toxic, this would ensure an advance in technique. Silicone rubber, obtainable in the form of tubing, is flexible and unaffected by repeated baking in a dry heat oven. Silicone greases remain