

An Einstein Paradox.

THE following, with amplified details to help discussion, is, I trust, a fair statement of the problem in Einstein's "Relativity" (Methuen). K, K₁ are together, each provided with a clock. The clocks agree at noon when K₁ starts moving in a straight line with uniform speed *v* (estimated in K's units).

Some time later, a light signal is flashed from a point L on the line, ahead of K₁, and is seen by K, K₁ at times *t*, *t'* on their respective clocks; KL = *x* of K's units of space and K₁L = *x'* of K₁'s. Then, according to Einstein,

$$(1) \dots x' = (x - vt) / \sqrt{1 - v^2/c^2},$$

$$(2) \dots t' = (t - vx/c^2) / \sqrt{1 - v^2/c^2},$$

where *c* = vel. of light in *vacuo*.

Since (1) does not contain *t'* we shall avoid the comparison of clocks by considering that equation only.

Now let us take the case of *x' = 0*; i.e. let the light signal be made exactly when K₁ reaches L.

Then by (1), *t = x/v*.

But *x/v* is the time on K's clock when K₁ reaches L; to this must be added the time for light to come from L.

Therefore true value of *t = x/v + x/c*.

Hence (1) appears to be fallacious.

In that case, also, *x² - c²t²* is not equal to *x'² - c²t'²*.

It is remarkable that Einstein actually considered the case of *x' = 0*, but overlooked the interpretation of it.

It may be interesting, possibly instructive, to consider how a "Newtonian philosopher" would deal with the above problem as soon as he became aware that the velocity of light was not negligible. There are three cases.

1. As above—the signal ahead of K and K₁, then

$$t = \frac{x - x'}{v} + \frac{x}{c} = \frac{(c+v)x - cx'}{cv},$$

$$t' = \frac{x - x'}{v} + \frac{x'}{c+v} = \frac{(c+v)x - cx'}{v(c+v)};$$

whence

$$t' = \frac{c}{c+v}t \quad \text{and} \quad x' = (1 + v/c)x.$$

2. The signal from behind K, K₁, so that *x, x'* are negative:

$$t = \frac{x - x'}{v} + \frac{(-x)}{c} = \frac{(c-v)x - cx'}{cv},$$

$$t' = \frac{x - x'}{v} + \frac{(-x')}{c-v} = \frac{(c-v)x - cx'}{v(c-v)},$$

equations which, as might be expected, are deducible from the previous pair by writing *(-c)* for *c*.

3. The signal from between K, K₁; or *x* positive, *x'* negative:

$$t = \frac{x - x'}{v} + \frac{x}{c},$$

$$t' = \frac{x - x'}{v} + \frac{(-x')}{c-v},$$

whence no neat results.

It seems reasonable to conclude that no single pair of equations, such as the Lorenz transformation, can meet all the cases!

R. W. GENESE.

40 London Road,
Southborough, Kent.

NO. 2796, VOL. III]

Longevity in a Fern.

I WONDER what is known of the duration of life in common herbaceous plants, other than annuals and biennials? The following instance may serve as a contribution to the lore of the subject.

About the year 1872 I found on the Mendip Hills a mature specimen of that curious sport of the hart's-tongue known as *Scolopendrium vulgare* var. *pevaferum-cornutum*, in which the mid-rib and the lamina part company at the apex of the frond, the mid-rib projecting as a horn, and the lamina forming a frilled pocket on the anterior surface. I transferred it to my father's garden in the same neighbourhood, where it has flourished ever since, retaining its peculiar character.

In 1917, as it was in danger of being choked by the growth of surrounding shrubs, I transplanted it. The stock had twice divided dichotomously, forming three crowns, of which one was dead. I placed the living ones where they had room to grow, and now they are as vigorous, and as young in appearance, as the original plant fifty years ago. As the plant was of unknown age when found, and looks no older after fifty years, its capacity for life seems indefinite.

F. J. ALLEN.

Cambridge, May 3.

The Recording Ultramicrometer.

THE recording ultramicrometer was first very briefly described before the Royal Dublin Society (Royal Dublin Society, xvi. p. 185, March 1921; cf. also NATURE, June 23, 1921, vol. 107, p. 523). Since its exhibition at the Edinburgh meeting of the British Association many short accounts of it have appeared in England and abroad. Many correspondents have requested further information, and, as some time may elapse before a full account of my investigations in this connexion are published, I take this opportunity of giving some practical hints to enable others to set up the apparatus.

In Fig. 1 the three-electrode valve is connected to

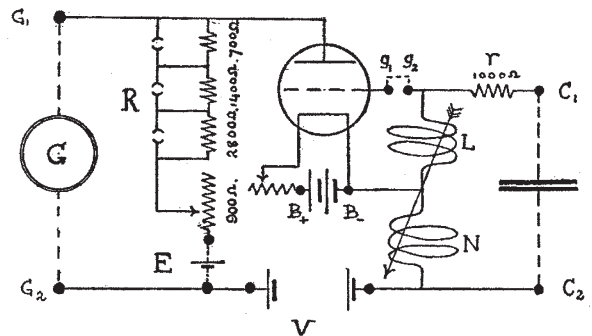

FIG. 1.—Diagram of connexions: B₁, 4 to 6 volts; V, 30 to 100; E, 1.5 to 6. L, N, about 10 cm., flat, 150 turns. G, aperiodic galvanometer, 10⁻⁸ amp. per div.

an oscillation circuit of the "Hartley" type, and in the anode circuit a sensitive galvanometer is introduced, its terminals being shunted by the "zero-shunt" E, R. The condenser C₁ C₂ of the oscillation circuit is formed by two parallel metal discs (say 5 cm. diameter). One of these may conveniently be adjustable by a fine micrometer screw, so that the capacity can be altered by turning the latter. As the plates are screwed together, increasing the capacity, it will generally be found that, from a certain point, the anode current increases, reaches a maximum, and finally rapidly recedes to its original value.