

if any, is supplied directly by actinium itself. From the point of view of the theory of radio-active changes, this shows that the change of actinium into AcX is a "ray-less" change.

A more complete account of these investigations will be published later.

T. GODLEWSKI.

McGill University, Montreal, January 2.

A Simple Model for Illustrating Wave-motion.

MACH's model for illustrating the transversal as well as the longitudinal wave is known to work in a beautiful manner. The arrangement for exciting the wave-motion is not, however, very simple. The fact that the period of a pendulum varies with the length of the string may conveniently be availed of for producing a wave-motion in a row of pendulum-bobs.

As shown in the annexed figure, a series of pendulums of equal length is suspended at equal intervals. Each ball hangs on two strings, each of which passes through the corresponding one in the row of holes in one of two parallel horizontal rods M and N; the strings pass through the holes from inside to outside, and are tied together to a horizontal rod L placed symmetrically above the two rods. One end of the upper rod is pivoted, while the

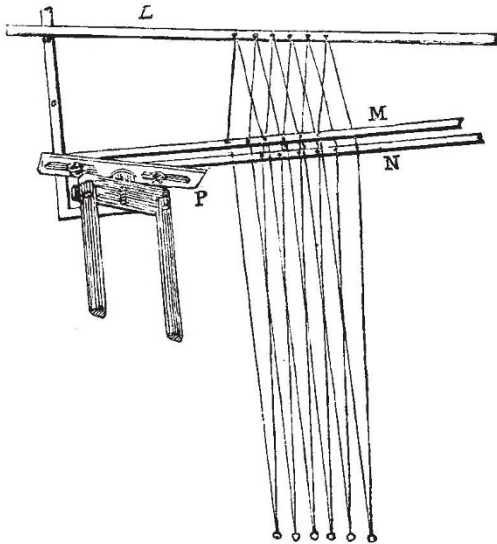

FIG. 1.

other can be raised to a suitable height. If this end be raised, the length of the pendulums increases from the end toward the other.

The two rods, M and N, can be separated or brought in contact by two links P and Q (not shown in the figure), attached to their ends. If the rods be in contact, the pendulums oscillate at right angles to the vertical plane containing the rod L; if they are separated, the pendulums oscillate in this plane. Hence, by the position of the links, the longitudinal as well as transversal oscillations of the pendulums can be excited at will.

To produce a wave-motion, the end of the upper rod L is raised, and then the two rods M and N are brought in contact. Then the pendulums are set in motion simultaneously by a long rod. After one or two minutes the phase-difference in each pendulum gradually increases, and a beautiful transversal wave-motion is produced. The wave-length becomes shorter and shorter; if a wave of a required wave-length is obtained, the rod L is lowered to its initial position. Each pendulum has then an equal length, so that wave-motion of a definite form incessantly proceeds from one end to another.

If the links be rotated, so as to separate the two bars M and N from each other, the plane of oscillation of each pendulum gradually changes, until the oscillation becomes

at last longitudinal. Then a regular longitudinal wave is observed to proceed from one end to another.

On the other hand, a longitudinal wave can first be excited, and then be transformed into a transversal one. Raising the end of the upper rod, and separating the two horizontal rods M and N, each pendulum is simultaneously set in a longitudinal motion by a long rod with receiving holes for pendulum-bobs. A longitudinal wave is gradually formed; if a wave of a suitable length be obtained, the rod L is lowered to its initial position; then wave-motion of a definite form is established. By turning the links the longitudinal wave is transformed into a transversal one.

Tokyo, Japan.

K. HONDA.

Recently Observed Satellites.

MAY I ask whether the small, distant, eccentric, and possibly retrograde satellites of Jupiter and Saturn, which have been discovered and seem likely to be discovered, ought not more properly to be regarded as cometary bodies, or a shoal of meteors not yet too much drawn out for visibility at a distance? Would it not be possible for the larger planets to be attended by such bodies, the orbits of which have been made moderately elliptical by an accidental perturbation? It is known that the larger planets are able to capture comets for the sun; is it possible that with the aid of their satellites and subsequent tidal action they may be able to catch a few for themselves?

OLIVER LODGE.

The University, Birmingham, January 20.

Compulsory Greek at Cambridge.

My experience of Greek at Cambridge is very similar to that of Mr. Willis, but the slight differences are, I think, instructive.

When I decided to go up to Cambridge to study mathematics and philosophy I was living abroad, and I crammed Greek just as Mr. Willis describes, except that I worked entirely alone. But on going in for the "Little Go," though I passed easily in translation, I failed by a few marks in Greek grammar. It was so near a thing that I thought I might pull through in December with a few hours more grind; but unfortunately I ran it too fine, and again failed by a few marks. This meant that I had to get up a complete new set of translation books for the following June, and to prevent further mistakes I went to a coach for the grammar part. I then passed, getting a second class. Like Mr. Willis, I can only say my present knowledge of the language is *nil*, although I had a double dose of it. It cannot for a moment be pretended that I got any insight into "Greek thought" which I could not have got equally well by reading a good translation. But I confess my opinion of the value of Greek thought was not raised by what I read—at best it only seemed to me creditable, considering how long ago it was written. But this may have been due to my resentment at being forced to waste time in an uncongenial study, when I was keen to get on to something else.

EDWARD T. DIXON.

Racketts, Hythe, Hants, January 20.

Super-cooled Rain Drops.

WALKING home from the university last night at about 8.45 p.m. an interesting phenomenon occurred.

Something was falling which at first appealed to one as hail, but I soon found that it was large rain drops evidently cooled below the freezing point; at the moment they struck objects such as one's hat, coat, or walking stick, &c., they instantly solidified in small hemispherical lumps; falling on the ground they gave it the appearance of a sheet of ice, but the roads were not slippery, as the solidified rain gave the road just a nice amount of roughness. The noise of the falling rain was very curious—a crackling noise, not unlike that of small electric sparks.

EDWARD E. ROBINSON.

The University, Birmingham, January 17.