



ARTICLE

# Autosomal dominant type IIa hypercholesterolemia: evaluation of the respective contributions of *LDLR* and *APOB* gene defects as well as a third major group of defects

Bruno Saint-Jore<sup>1,\*</sup>, Mathilde Varret<sup>1</sup>, Christiane Dachet<sup>1</sup>, Jean-Pierre Rabès<sup>1,2</sup>, Martine Devillers<sup>1</sup>, Danielle Erlich<sup>3</sup>, Patricia Blanchard<sup>4</sup>, Michel Krempf<sup>4</sup>, Denis Mathé<sup>5</sup>, Bernard Chanu<sup>5</sup>, Bernard Jacotot<sup>5</sup>, Michel Farnier<sup>6</sup>, Catherine Bonaïti-Péllié<sup>7</sup>, Claudine Junien<sup>1,2</sup> and Catherine Boileau<sup>1,2</sup>

<sup>1</sup>INSERM U383, Université René Descartes, Paris V, Hôpital Necker-Enfants Malades, Paris; <sup>2</sup>Laboratoire de Biochimie et de Génétique Moléculaire, CHU Ambroise Paré AP-HE, Boulogne; <sup>3</sup>Service de Biochimie, CHU Saint-Louis, Paris; <sup>4</sup>Service d'Endocrinologie, CHU Hotel Dieu, Nantes; <sup>5</sup>Service de Médecine Interne, CHU Henry Mondor, Créteil; <sup>6</sup>Point Médical, Dijon; <sup>7</sup>INSERM U351, Institut Gustave Roussy, Villejuif, France

Autosomal dominant type IIa hypercholesterolaemia (ADH) is characterised by an elevation of total plasma cholesterol associated with increased LDL particles. Numerous different molecular defects have been identified in the LDL receptor (*LDLR*) and few specific mutations in the apolipoprotein B (*APOB*) gene resulting in familial hypercholesterolaemia and familial defective apoB-100 respectively. To estimate the respective contribution of *LDLR*, *APOB* and other gene defects in this disease, we studied 33 well characterised French families diagnosed over at least three generations with ADH through the candidate gene approach. An estimation of the proportions performed with the HOMOG3R program showed that an *LDLR* gene defect was involved in approximately 50% of the families ( $P = 0.001$ ). On the other hand, the estimated contribution of an *APOB* gene defect was only 15%. This low estimation of ADH due to an *APOB* gene defect is further strengthened by the existence of only two probands carrying the *APOB* (R3500Q) mutation in the sample. More importantly and surprisingly, 35% of the families in the sample were estimated to be linked to neither *LDLR* nor *APOB* genes. These data were confirmed by the exclusion of both genes through direct haplotyping in three families. Our results demonstrate that the relative contributions of *LDLR* and *APOB* gene defects to the disease are very different. Furthermore, our results also show that genetic heterogeneity is, generally, underestimated in ADH, and that at least three major groups of defects are involved. At this point, the contribution of the recently mapped FH3 gene to ADH cannot be assessed nor its importance in the group of 'non *LDLR* / non *APOB*' families. *European Journal of Human Genetics* (2000) 8, 621–630.

**Keywords:** autosomal dominant type IIa hypercholesterolaemia; familial defective apolipoprotein B-100; familial hypercholesterolaemia; genetic heterogeneity; LDL receptor; apolipoprotein B

Correspondence: Professor C Boileau, INSERM U383, Hôpital Necker-Enfants Malades, Clinique M Lamy, 149–161 Rue de Sévres, 75743 Paris Cedex 15, France. Tel: + 33 1 44 49 44 85;

Fax: + 33 1 47 83 32 06; E-mail: boileau@necker.fr

\* Present address: INSERM U321, Hôpital Pitié-Salpêtrière, Paris, France

Received 7 January 2000; revised 17 April 2000; accepted 27 April 2000

## Introduction

Type IIa hypercholesterolaemia is characterised

- (1) biologically, by an elevated concentration of plasma cholesterol,
- (2) clinically, by xanthomas, arcus corneae, and premature coronary heart disease, and
- (3) genetically, usually by a dominant mode of inheritance.<sup>1</sup>

The elevation of total cholesterol (TC) is due to an increase of cholesterol bound to low density lipoprotein particles (LDL), above the 95th percentile cut-off for the general population.

It was generally assumed that autosomal dominant hypercholesterolaemia (ADH) is exclusively due to a defect either in the *LDLR* (low density lipoprotein receptor) or the *APOB* (apolipoprotein B) gene. The term familial hypercholesterolemia (FH) has been applied broadly to patients presenting with a mutation in the *LDLR* gene. This gene encodes a cell surface glycoprotein that mediates the removal from blood of cholesterol carrying LDL particles via apolipoprotein B.<sup>1,2</sup> The *LDLR* gene in 19p13 spans 45 kilobases and comprises 18 exons.<sup>3</sup> Over 500 different mutations have been reported.<sup>4</sup> However, individuals with elevated LDL cholesterol and normal LDL receptor activity have been reported as well as the absence of mutation in the *LDLR* gene of FH probands.<sup>5</sup> Furthermore, no mutations are found after systematic sequencing of the *LDLR* gene in about 15% of probands.<sup>6,7</sup> Among the latter, some probands probably do not carry a mutation in this gene. Thus FH does not account for all familial cases of high LDL cholesterol levels.

In hypercholesterolaemic patients, simultaneous measurement of turnover rates of autologous and normal homologous LDL demonstrated fractional clearance rates for autologous LDL that were significantly lower than those for normal homologous LDL.<sup>8</sup> By *in vitro* binding studies, Innerarity *et al*<sup>9</sup> demonstrated that in one case this reduced binding was the result of a defect in apolipoprotein B-100. Further studies of the *APOB* gene identified a single nucleotide substitution from G → A, at nucleotide 10 699, which resulted in a glutamine for an arginine substitution at residue 3500 (R3500Q).<sup>10</sup> This molecular defect segregated in some families designated as presenting with familial defective apolipoprotein B-100 (FDB). This mutation was usually associated with the same haplotype, suggesting a common European ancestral mutation.<sup>11,12</sup> Interestingly, a second hypercholesterolaemic mutation was described at the same codon resulting in a tryptophan for an arginine substitution APOB R3500W.<sup>13</sup> Finally, Pullinger *et al*<sup>14</sup> reported a third mutation which decreases LDL binding activity: the APOB 3531 (R3531C) mutation at nucleotide 10 800, which results in a cysteine for an arginine substitution. However, in more recent studies, this mutation was not found associated with hypercholesterolaemia and/or coronary artery disease.<sup>15,16</sup>

These mutations are the only reported defects of the *APOB* gene associated with hypercholesterolaemia. Finally, we recently reported on the mapping of a third major gene named FH3 at chromosome 1p34–p32, demonstrating the existence of further genetic heterogeneity for ADH.<sup>17</sup>

The prevalence of monogenic hypercholesterolaemia in the general population has been determined on several occasions. Using the data from genetic analysis of hyperlipidaemia among consecutively studied survivors of myocardial infarction, Goldstein *et al*<sup>18</sup> estimated a minimal heterozygote frequency for familial forms of isolated hypercholesterolaemia of 1 in 500 individuals of the general population. Subsequently, molecular defects in the *LDLR* gene were identified. It was generally assumed that these defects accounted for all the heterozygous forms of hypercholesterolaemia and therefore the FH heterozygote frequency was considered identical to that previously estimated for monogenic hypercholesterolaemia (ie 1/500). However, genetic heterogeneity was demonstrated through the identification of FDB whose prevalence was estimated between 1/500 and 1/1000.<sup>19,20</sup> Furthermore, as early as 1974, Morganroth *et al*<sup>21</sup> identified several probands presenting with 'pseudohomozygous type II hypercholesterolaemia' which is now known as 'familial recessive hypercholesterolaemia type IV' (FH4).<sup>22</sup> Probands with this autosomal recessive disease have normal LDL particles and LDL receptor activity, but a significant reduction in hepatic LDL uptake similar to that observed in FH homozygotes. Since phenotype of FH4 patients is strikingly identical to that of FH homozygous patients, it indicates the involvement of another group of defects. Finally, Hobbs *et al*<sup>23</sup> clearly demonstrated that a mutation in the *LDLR* gene is not always associated with an FH clinical presentation because of the existence of 'compensatory' mechanisms. These observations show that monogenic type IIa hypercholesterolaemia is an heterogeneous group of disorders whose prevalence cannot be properly assessed through only clinical and biological data.

Several studies using various approaches (functional tests,<sup>7</sup> molecular<sup>6,24</sup> or genetic analyses<sup>25,26</sup>) have assessed the contribution of either *LDLR* or *APOB* gene defects to ADH. However, to our knowledge, no study has as yet been designed to simultaneously evaluate, and in a single sample, the respective contributions of FH and FDB to autosomal dominant type IIa hypercholesterolaemia. The need for these data has become important for diagnostic and research purposes since the recent localisation of the new FH3 locus.<sup>17</sup> To fill this gap, we used the candidate gene approach<sup>27</sup> in a sample of French families. Segregation of ADH with polymorphic markers of the *LDLR* and *APOB* genes was studied in the families. Linkage analyses were performed and followed by computerised admixture tests:

- i) HOMOG computes likelihoods under the hypothesis of two family types, one with linkage and the other one without linkage between the disease and the gene

tested, and estimates the proportion of linked families; and

- ii) HOMO3R calculates likelihoods under the assumption that a disease is linked to gene 1 (proportion  $\alpha$ ) in some families, and to gene 2 (proportion  $\beta$ ) in other families on another chromosome against the hypothesis that some families may be linked to an other unidentified gene (proportion  $\gamma$ ) and estimates the three proportions

These tests allowed us to estimate, in our sample, the proportion of families with an *LDLR* ( $\alpha$ ) or an *APOB* ( $\beta$ ) gene defect. Furthermore, they also demonstrated the existence of a third group of families ( $\gamma$ ) associated with mutations within one, or several, different locus (i).

## Materials and methods

### Probands and families

Probands were ascertained among consecutive patients from lipid clinics belonging to four medical centres located either in the western or central parts of France or the Paris area. The following selection criteria were used: total and LDL cholesterol above the 95th percentile when compared with sex and age matched French populations,<sup>28</sup> triglycerides below 1.3 mmol/L, personal or documented familial xanthomas, and/or arcus corneae, and early coronary artery disease. Lipid measurements were repeated to ascertain the existence of primary type IIa hypercholesterolaemia. At the same time, family history and pedigrees were investigated. Forty-five probands matching the selection criteria and belonging to multiplex families displaying the disease over at least three generations were selected for the study. Family members were examined and their lipid levels repeatedly determined. Subsequently, only 36 families were selected (9 being eliminated because of existence of elevated triglyceride levels in some first-degree relatives, suggesting the possibility of familial combined hyperlipidaemia).

Genetic analyses using multi-allelic markers from different chromosomal regions led to the exclusion of three families for non-paternity. Finally, a total of 252 subjects from 33 hypercholesterolaemic families (with a mean of 2.3 sibs and representing 172 meioses) was included in the study (Figure 1). Probands (mean age around 49 years old) had mean total cholesterol of  $10.15 \pm 2.72$  mmol/L and  $7.29 \pm 2.01$  mmol/L, before and after hypocholesterolaemic treatment, respectively. Mean LDL cholesterol were  $7.03 \pm 1.91$  mmol/L and  $5.58 \pm 2.01$  mmol/L, before and after treatment, respectively. Mean triglycerides was  $1.01 \pm 0.29$  mmol/L. Phenotypic status for family members was initially established by the recruiting team on each site and was independently and blindly confirmed by members from other teams. A bimodal distribution was observed for the standardised total cholesterol values of all first-degree relatives. A bimodal distribution was also observed for raw

LDL-cholesterol values. Since this parameter is calculated and not directly measured, standardisation could not be performed. This explains the strong overlap observed in Figure 2. Conversely, triglycerides values displayed a unimodal distribution similar to that of the normal population (data not shown). Finally arcus, corneae, myocardial infarction at early age, and xanthomas were variously observed among affected subjects in agreement with well documented variable expressivity in this disease.

### *LDLR* gene analysis

Four biallelic polymorphisms of the *LDLR* gene were tested by PCR amplification: *TaqI*, *BstEII*, *HincII*, and *AvaII* located in introns 4 and 12 and in exons 12 and 13 respectively.<sup>25,29,30</sup> Four multi-allelic markers were also tested, a polymorphism associated with an *Alu* sequence located within intron 15,<sup>31</sup> a (CA)<sub>n</sub> (D19S394), a (TAA)<sub>n</sub> (D19S594) and a (TA)<sub>n</sub> repeat located respectively flanking, in intronic sequences and in the 3' end of the *LDLR* gene.<sup>32,33</sup> The *Alu* sequence was amplified by PCR on a 9600 Geneamp (Perkin-Elmer Biosystems, Courtaboeuf, France) for 30 cycles (94°C for 20 s, 56°C for 20 s, 72°C for 30 s) with 20 mM of each primer, 1 mM MgCl<sub>2</sub>, and radiolabelled  $\alpha^{32}\text{P}$  dATP. PCR products were migrated on a 5% non-denaturing polyacrylamide gel at 20 V/cm, and then the gel was dried and exposed overnight on to autoradiographic film (Kodak, Paris, France). For the di- and tri-nucleotide repeats, two volumes of dye containing 95% formamide were added to each amplification product before electrophoresis on 10% denaturing polyacrylamide gels at 40 V/cm. DNAs were transferred to a Hybond N<sup>+</sup> membrane (Amersham Pharmacia Biotech Europe, Orsay, France) and fixed in NaOH 0.4 M. Membranes were hybridised with 20 ng of one of the PCR primers, radiolabelled by a 3' tailing reaction (Boehringer, Mannheim, Germany), and incubated at 42°C for 3 h in phosphate buffer 0.13 M pH7, SDS 7%, NaCl 0.5 M and PEG 10%.<sup>34</sup> Membranes were washed and exposed to autoradiographic film for 4 to 10 hours. The (TA)<sub>n</sub> repeat was originally described as a triallelic marker (7, 8, and 10 repeats). However, we have identified two other alleles with 11 and 12 repeats.

### *APOB* gene analysis

The multiallelic 3'HVR<sup>11</sup> and the (TG)<sub>n</sub> repeat<sup>35</sup> were PCR amplified and their alleles were detected as described above. Running conditions for the 3'HVR marker were on a 4% denaturing acrylamide gel at 50 V/cm. An insertion/deletion polymorphism (SP) located in the signal peptide of the gene was PCR-amplified and run in an 8% non-denaturing polyacrylamide gel.<sup>36</sup> Screening for the R3500Q and R3531C mutations in the *APOB* gene were performed by PCR-mediated site-directed mutagenesis followed by *MspI* and *MluI* digestions. Two bands of smaller molecular weight were observed when either mutation was present.<sup>37</sup>

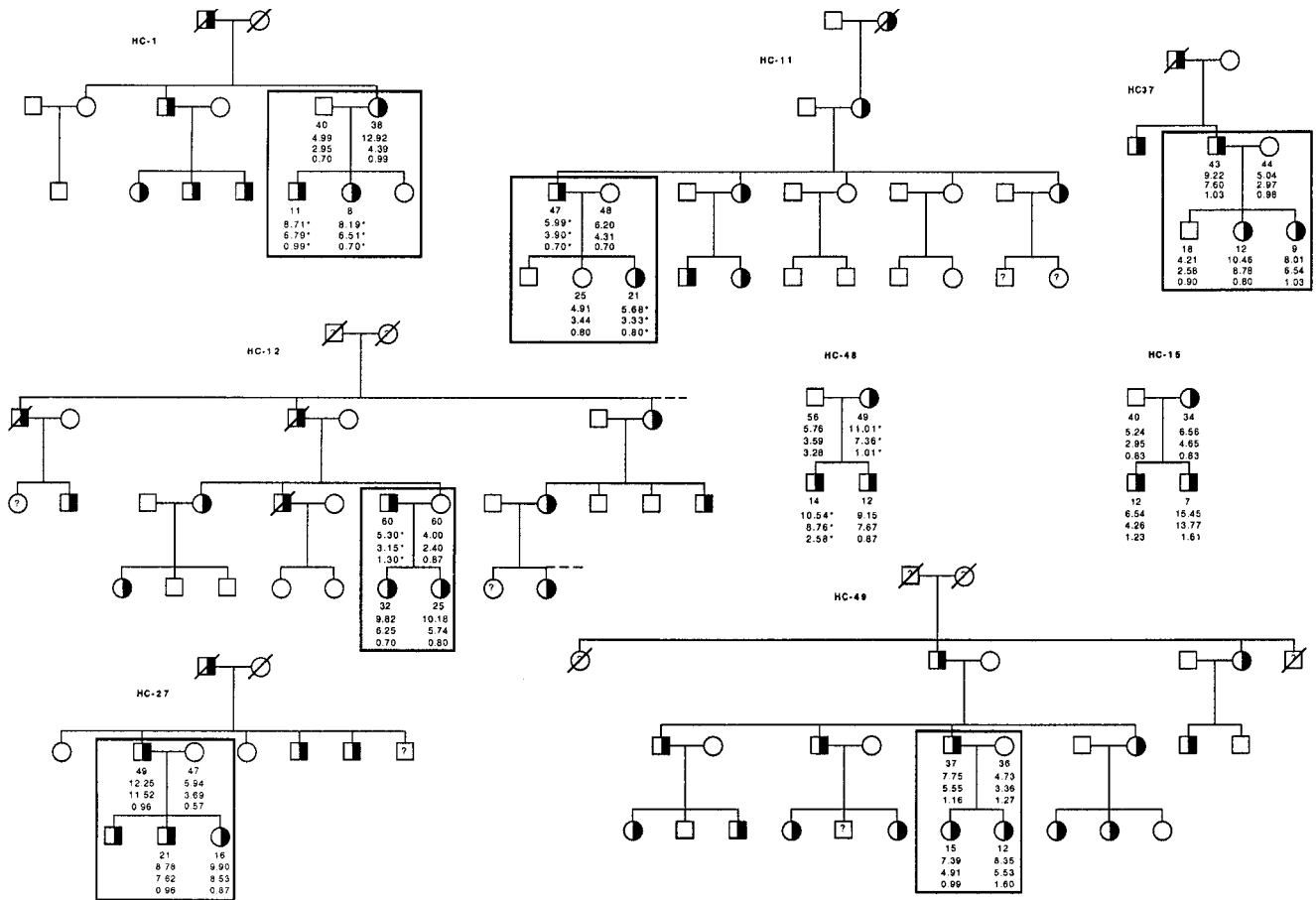

**Figure 1** Pedigrees of eight out of 33 families showing autosomal dominant inheritance of the hypercholesterolaemic trait. Families used in the study are boxed. Half-filled symbols denote affected individuals, open symbols denote unaffected members, open symbols with a question mark represent individuals with unknown status. Under each patient's symbol are listed: age at lipid measurement, total cholesterol, LDL-cholesterol, and triglycerides. Asterisks describe values obtained after hypocholesterolaemic treatment and diet. All lipid values are expressed in mmol/L.

### Genetic studies

Pairwise lod scores were computed at 8 recombination fraction ( $\Theta = 0.001, 0.005, 0.01, 0.02, 0.03, 0.04, 0.05, \text{ and } 0.10$ ) using the MLINK subprogram of the LINKAGE package (version 5.1).<sup>38</sup> Lod score analyses were performed with a complete or incomplete penetrance (1.0 or 0.9, respectively) for heterozygous individuals. The admixture estimation test<sup>39</sup> was performed using two HOMOG programs: HOMOG and HOMOG3R.<sup>40</sup> HOMOG computes likelihoods under the hypothesis of two family types, one with linkage and the other one without linkage to the locus tested and estimates the proportion of linked families. HOMOG3R calculates likelihoods under the assumption that a trait is linked to locus 1 (proportion  $\alpha$ ) in some families, and to locus 2 (proportion  $\beta$ ) in other families on another chromosome, against the hypothesis that some families may be linked to another unidentified locus (proportion  $\gamma$ ) and estimates the three proportions. We used this program HOMOG3R, where

both loci are candidate genes and with lod scores evaluated at  $\Theta = 0.001$ .

Linkage homogeneity was also tested between families sampled in the Paris area and various centres from the western part of France. We used the following property of the maximum likelihood ratio test. When a given sample is divided into  $k$  subsamples, if  $L_i$  is the maximum likelihood for the whole sample and  $L_i$  the maximum likelihood for subsample  $i$ , then  $-2\ln(L_i/\sum L_i)$  asymptotically follows a  $\chi^2$  distribution with  $n(k-1)$  degrees of freedom, where  $n$  is the number of estimated independent parameters. In our case, the estimated parameters were  $\alpha$  and  $\beta$  since thetas were set at 0.001.

### Results

#### Genetic analysis for the *LDLR* and *APOB* genes

Molecular defects responsible for ADH have been identified in two genes: *LDLR* and *APOB*. To estimate their respective

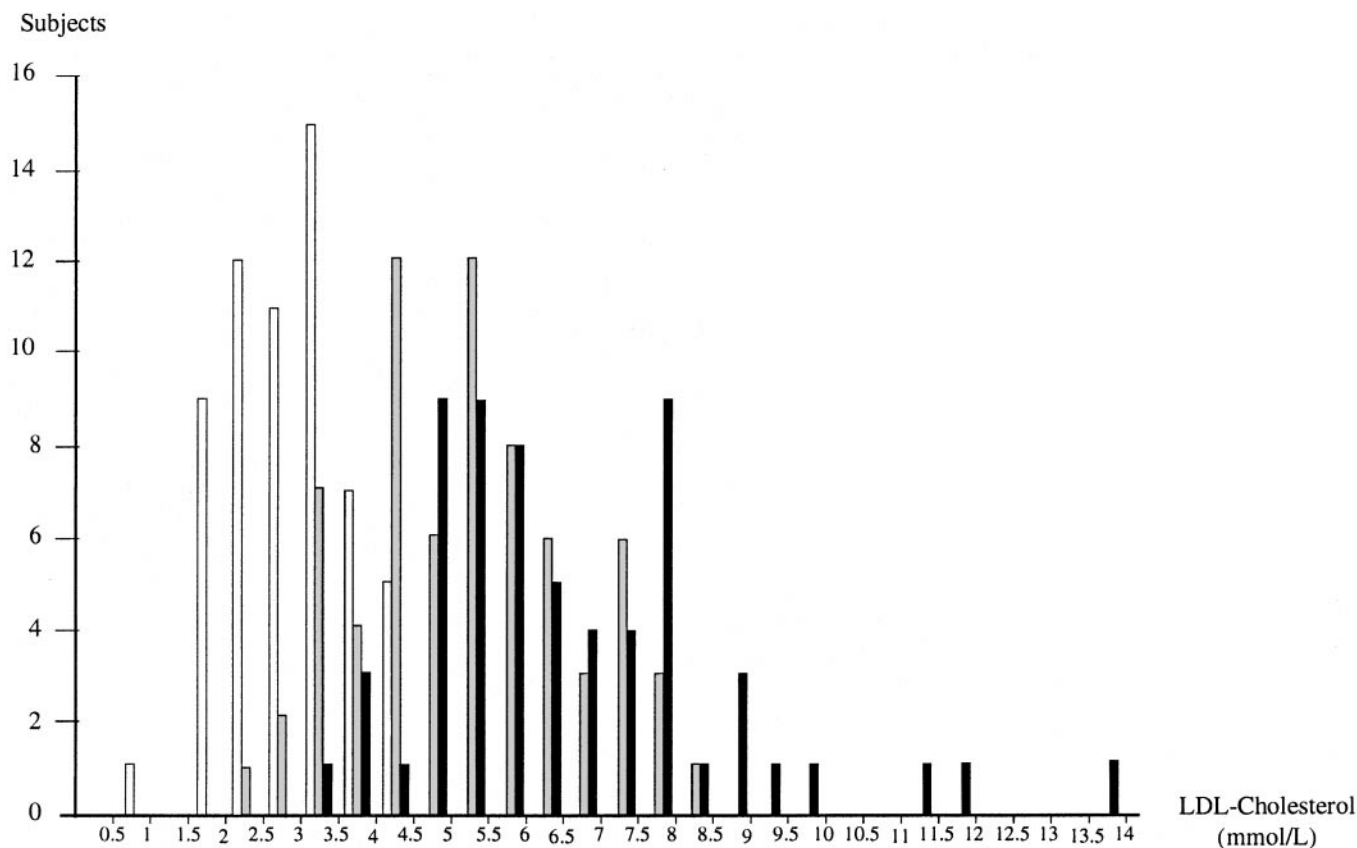

**Figure 2** Distribution of LDL cholesterol values. Bars represent the number of first degree relatives per category; open bars represent non-affected subjects, grey bars affected individuals with treatment and/or diet for whom detailed lipid values prior to treatment were not available, and black bars affected individuals prior to treatment.

contribution to the disease, we recruited 33 families (252 individuals) with a compatible autosomal dominant transmission of this trait over three generations (Figure 1). To evaluate the families linked to either *LDLR* or *APOB* genes, individuals were first haplotyped using polymorphic *LDLR* and *APOB* gene markers, respectively. Then a classic genetic linkage analysis was performed using the MLINK program. Because of the small size of many of the families, mostly exclusions could be definitively ascertained.

For the *LDLR* gene markers, linkage disequilibrium between different polymorphic markers considerably reduced the overall informativity at this locus. Therefore we increased the number of polymorphic markers tested to eight, resulting in 30 informative families out of 33 (Table 1):

- 1) linkage (lod score  $\geq 2.00$  under the candidate gene approach) was reached in HC5 family;
- 2) an exclusion (lod score  $\leq -2.00$ ) could be definitely demonstrated in 23% (7/30) of the informative families (HC2, 6, 13, 32, 33, 47, and 70);
- 3) 20 families displayed small positive lod scores; and

- 4) two families displayed small negative lod scores

These two groups included both linked and unlinked families but because of the size of the families the exclusion or linkage threshold could not be reached.

- 5) only three families remained non-informative (lod score = 0.00) because probands were homozygous for all tested markers (HC3, 31, and 36).

These results showed that at least 23% of the ADH families of the sample were not carrying an *LDLR* gene defect.

For the *APOB* locus, 30 families were informative (Table 1):

- 1) an exclusion was definitely demonstrated in 43% (13/30) of the informative families;
- 2) 17 families displayed low positive or negative lod scores;
- 3) only three families remained non-informative

These results showed that, in this population, an important fraction of ADH (43%) is not due to a defect in the *APOB* gene. In addition, we looked for the FDB mutations at amino

**Table 1** Multipoint lod scores between familial type IIa hypercholesterolaemia and *LDLR* and *APOB* gene markers at  $\theta=0.001$  in 33 families investigated performed under complete and 0.9 penetrance

Family	Total number of subjects (n=252)	Affected subjects (n=117)	Number of meioses (n=172)	Lod scores at penetrance: 1.0		Lod scores at penetrance: 0.9	
				<i>LDLR</i>	<i>APOB</i>	<i>LDLR</i>	<i>APOB</i>
HC1	4	3	2	0.30	0.30	0.30	0.30
HC2	38	6	29	-4.25	-3.82	-2.43	-1.89
HC3	5	2	3	0.00	0.60	0.00	0.52
HC5	15	6	12	2.23	-2.34	2.09	-2.34
HC6	43	11	32	-17.62	-9.59	-5.34	-4.22
HC8	5	4	3	0.30	-1.86	0.30	-1.78
HC11	4	2	2	0.30	0.30	0.26	0.26
HC12	4	3	2	0.30	-2.05	0.30	-1.97
HC13	6	3	4	-2.40	-2.10	-1.43	-0.18
HC14	11	7	14	1.75	-5.86	1.71	-3.30
HC15	4	3	2	0.30	0.00	0.30	0.00
HC19	4	2	2	0.30	-2.40	0.26	-0.73
HC20	7	4	5	0.36	-2.05	0.32	-2.00
HC23	6	2	4	0.30	0.30	0.26	0.26
HC24	5	3	3	0.30	0.60	0.30	0.56
HC27	4	3	2	0.30	0.30	0.30	0.30
HC30	4	2	2	0.30	-2.40	0.26	-0.73
HC31	4	2	2	0.00	0.30	0.00	0.26
HC32	4	3	2	-2.05	0.00	-1.98	0.00
HC33	4	3	2	-2.05	0.30	-1.98	0.30
HC34	5	3	3	0.30	-2.05	0.30	-1.98
HC35	5	4	3	-1.86	-1.86	-1.78	-1.79
HC36	4	2	2	0.00	-2.40	0.00	-0.73
HC37	5	3	3	0.60	-2.40	0.56	-0.44
HC38	4	3	2	0.30	0.30	0.30	0.30
HC42	6	5	5	0.86	0.73	0.86	0.73
HC43	5	4	3	0.60	0.46	0.60	0.46
HC44	5	2	3	-0.21	-0.65	-0.10	-0.44
HC45	4	2	2	0.30	0.30	0.26	0.26
HC47	5	3	3	-2.40	0.00	-2.29	0.00
HC48	4	3	2	0.30	-2.05	0.30	-1.97
HC49	4	3	2	0.30	0.30	0.30	0.30
HC70	15	6	10	-5.01	1.50	-3.18	1.45

acids R3500Q and R3531C in all probands and their spouses, by PCR-mediated site-directed mutagenesis analysis. In the HC24 and HC70 families, probands and several affected members were found positive for the *APOB* (R3500Q) mutation (data not shown). This direct analysis showed that *APOB* contribution was at least of 6% (2/33).

Importantly, when combined together these results underscored the existence of a third group of families that showed an exclusion for both genes (HC2, HC6, and HC13, see below). Thus, when considering only the sub-sample of families in which informativity was obtained at both loci, 11% (3/27) of families are unlinked to either locus.

#### Estimation of the proportions of families associated with *LDLR*, *APOB* or 'non-*LDLR*, non-*APOB*' gene defects

To estimate the proportion of families linked to either of the candidate genes, we used the HOMOG computer package that analyses the likelihoods computed with the MLINK program. Different analyses were performed using either the *LDLR* or the *APOB* gene markers alone (HOMOG), and using both *LDLR* and *APOB* gene markers and testing for the evidence of a third family type (HOMOG3R). We did these

analyses with different parameters corresponding to different models. Under the first hypothesis, penetrance was considered complete assuming that every individual carrying a mutation was hypercholesterolaemic. In the second model the penetrance was rated at 0.9 for heterozygotes. This second model was investigated to take into account the observed overlap of the distributions of cholesterol levels between affected and unaffected subjects in our sample and also reported by other groups,<sup>1</sup> as well as the single report of incomplete penetrance in a large FH family.<sup>23</sup>

The HOMOG tests were highly significant and unsurprisingly confirmed the existence of genetic heterogeneity in the sample. However, they estimated the proportion of families linked to *LDLR* gene defects at  $\alpha = 54\%$  and *APOB* gene defects were estimated  $\beta = 23\%$  and  $20\%$  according to the two different models (penetrance = 1.0 and 0.9, respectively) (Table 2). These results confirmed that familial type IIa hypercholesterolaemia was heterogeneous since *LDLR* and *APOB* gene mutations were already identified. However, the contribution of the *LDLR* locus was much higher than that of the *APOB* locus. These results also showed that defects in the *LDLR* and the *APOB* genes did not account for all cases of

**Table 2** Results of HOMOG analyses for the *LDLR* and *APOB* genes

	<i>LDLR</i>	<i>APOB</i>
Penetrance 1.0	$\alpha = 54\%$ (23–79)* $Z_{\max}(\Theta) = 5.18$ (0.001) $P = 0.0001$	$\beta = 23\%$ (0–54)* $Z_{\max}(\Theta) = 0.89$ (0.005) $P = 0.021$
Penetrance 0.9	$\alpha = 54\%$ (23–80)* $Z_{\max}(\Theta) = 4.87$ (0.001) $P = 0.002$	$\beta = 20\%$ (0–49)* $Z_{\max}(\Theta) = 0.87$ (0.005) $P = 0.021$

\*confidence interval

ADH in our sample. Since the HOMOG program performs its statistical analysis testing the existence of linkage between the trait and a *single* locus, the proportion  $\gamma$  of 'non *LDLR* / non *APOB*' families is more adequately estimated by using the HOMOG3R sub-program which tests for linkage between the trait and *two distinct* loci under the candidate gene hypothesis. This test confirmed the values obtained previously for the *LDLR* gene with  $\alpha = (50\%)$  and slightly reduced the contribution  $\beta$  of the *APOB* gene to 15%. More importantly, it estimated at 35% the proportion ( $\gamma$ ) of families linked neither to the *LDLR* nor the *APOB* genes. Identical proportions were obtained whatever the model used and both tests were highly significant ( $P = 0.0001$ ).

Since these families originated from two different geographical areas, we tested the homogeneity of our populations by a linkage homogeneity test between samples. The predivided sample test was applied, using the maximum likelihood values obtained for each family sub-sample with the HOMOG3R program. The test showed no statistically significant difference between the 13 families sampled in Paris and the 19 from the other French centres ( $\chi^2_2 = 1.14$ ,  $P < 0.50$ ).

#### Identification of three 'non-*LDLR* / non-*APOB*' families

As the contribution of 'non-*LDLR* / non-*APOB*' families was estimated at 35%, we sought to distinctly identify families that would definitively demonstrate the involvement of a third locus. A careful analysis of segregation of markers in our sample disclosed the presence of three families in whom exclusion of the two candidate genes *LDLR* and *APOB* could be demonstrated (HC2, HC6 and HC13) (Figure 3). In family HC2, at the *LDLR* locus the affected proband transmitted the same allele (H2, A1, T3) to her affected and non-affected sons. At the *APOB* locus, the proband also transmitted the same allele (T3, S2, V7) to her two sons. A similar analysis performed for family HC6 demonstrates the existence of another non-*LDLR* / non-*APOB* family (Figure 3). Furthermore, these data were supported by cellular and molecular analyses. Genetic exclusions observed for the *LDLR* gene were confirmed by *in vitro* studies showing that LDL receptor activity in the probands from both families was equal to that of a normal control subject (data not shown). For the *APOB*

gene, genetic exclusion was confirmed by absence of two *APOB* R3500Q and R3531C mutations. Finally, genotyping of members at large in the two families identified further recombinants among affected and unaffected subjects and confirmed the exclusion data for both candidate genes (data not shown). In the case of family HC13, samples could not be obtained from affected individuals to evaluate LDL receptor activity.

#### Discussion

The aim of this study was to evaluate the respective contributions of *LDLR*, *APOB* and other gene defects to dominant type IIa hypercholesterolaemia using genetic linkage analysis and homogeneity tests for linkage in a sample of French families. The families investigated were ascertained through probands that were identified among consecutive patients from the four centres over a period of 2 years. Only nuclear families were studied and, whenever possible, multiplex families were sampled and explored. The exclusion criteria used for the probands were in agreement with generally accepted criteria<sup>41</sup> and rather conservative, since families with subjects presenting triglycerides levels superior to 1.3 mmol/L were excluded. An overlap of the distribution is observed with LDL-cholesterol values (Figure 2). This is due to the unavailability of published reference values of LDL-cholesterol. However, when considering the age of the subjects, their status can be unequivocally ascertained.

Results from the HOMOG analyses showed the existence of genetic heterogeneity in the sample. In effect, the hypothesis for linkage heterogeneity (H2 Vs H1) was significant for the *LDLR* and *APOB* genes (Table 2). The tests also showed that LDL receptor defects were by far the most common in our sample of ADH families since they were estimated to account for 54% of the cases. Conversely, the contribution of the *APOB* gene defects was estimated at only 20–30%. There is a discrepancy between these figures and the identification of only two families (HC24 and HC70) who carry the *APOB* R3500Q mutation. Therefore, the contribution of this mutation was estimated at only 6% in the sample of ADH families. This is in agreement with other European populations as reported by Tybjærg-Hansen *et al.*,<sup>42</sup> Talmud *et al.*,<sup>43</sup> Miserez *et al.*<sup>44</sup> and Rabès *et al.*<sup>37</sup> The discrepancy can be explained by the rather large confidence interval associated with the results of the HOMOG tests for the *APOB* gene markers (Table 2). However, since the genetic approach we used analyses the possible involvement of a candidate gene and not of a single mutation, our sample could contain a few families carrying still unidentified hypercholesterolaemic mutations of the *APOB* gene.

Careful observation of *APOB* and *LDLR* gene haplotypes as well as linkage data revealed that in three families (HC2, HC6, and HC13) the defect was linked to neither of the candidate genes. Therefore to estimate the proportion  $\gamma$  of 'non-*LDLR* / non-*APOB*' families, we used a more adequate

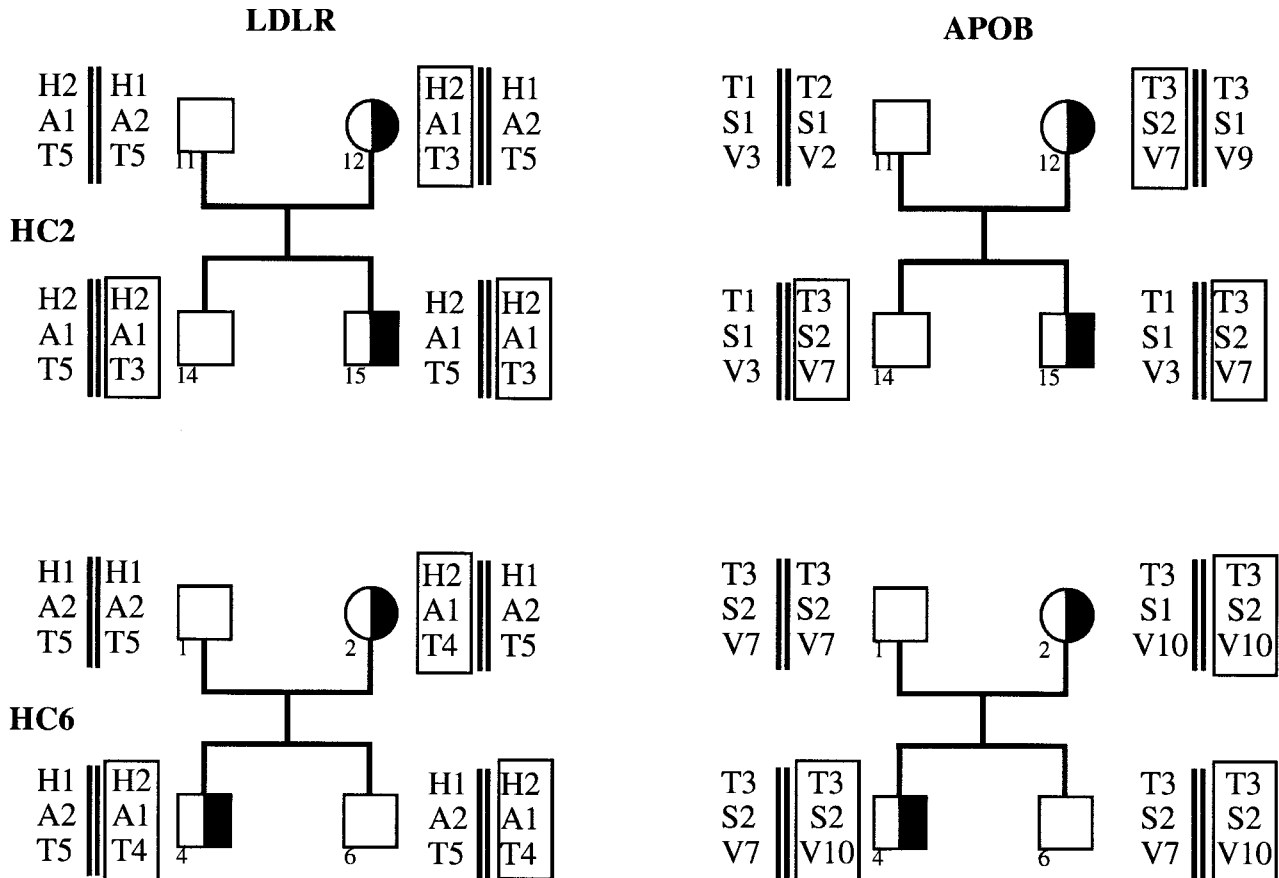

Figure 3 Exclusion of the *LDLR* and *APOB* gene markers in two hypercholesterolaemic families HC2 and HC6. Haplotypes for each family member are shown in the following order: *LDLR* gene haplotypes [H: *Hind*II, A: *Avall*, T: (TA)<sub>n</sub>], *APOB* gene haplotypes [T: (TG)<sub>n</sub>, S: SP, V: 3'HVR]. 1: Absence of the polymorphic site or presence of the insertion. 2: Presence of the polymorphic site or of the deletion. TG 1, 2, 3 ↔ 15, 14, 13 repeats, respectively. TA 3, 4, 5 ↔ 10, 8, 7 repeats, respectively. 3'HVR: 12 alleles have been identified in our laboratory. They are numbered from 1 to 12 according to their molecular weight. Allele no. 2 has 48 repeats and is often associated with the *APOB* R3500Q mutation. In each family haplotypes of interest are boxed.

program: HOMOG3R. It tests for heterogeneity using simultaneously linkage data obtained with markers from the two candidate genes. The tests were highly significant and clearly demonstrated the existence of greater genetic heterogeneity. The new estimated proportions for *LDLR* and *APOB* genes were at 55% and 15%, respectively, not statistically different from the estimations previously obtained with the HOMOG tests. *LDLR* gene defects were still the most common cause of ADH despite the tested hypothesis of existence of three loci associated with the disease. The test confirmed the low contribution of *APOB* gene defects. Finally, it also showed that  $\gamma$  accounted for 35% of the mutations in our sample, thus second to *LDLR* gene defects.

The results of the genetic analyses were confirmed in two families (HC2 and HC6) by the LDL receptor assay which was normal for both probands (data not shown). Ultracentrifugation analyses of HC2 and HC6 probands' plasma showed a typical type IIa profile with an elevation of LDL particles

similar to the pattern observed for patients with an *LDLR* mutation (data not shown). The clinical and biological findings in these families are identical to those of other type IIa families, but are in general mild and therefore closer to FDB than FH.<sup>17</sup> At the present stage, the identity of the third locus is unknown, but we proved that  $\gamma$  represents a genetically heterogeneous class of defects. In effect, through a genome-wide search, we mapped at 1p34-p32 the disease locus for HC2 and called it 'FH3'.<sup>17</sup> Because of the size of the region on chromosome 1 (8-9 cM), it is impossible to perform admixture tests using anonymous loci markers to evaluate the proportion of families linked to the FH3 locus. However, linkage was excluded between FH3 and the disease in HC6 family. Taken together these results clearly demonstrate that there are at least four loci involved in ADH and that  $\gamma$  is a heterogeneous class of molecular defect. However, because of the numerous proteins, enzymes and receptors involved in cholesterol homeostasis, it is not surprising that there are

several 'non-LDLR / non-APOB' loci involved in ADH. Identification of these loci will probably unravel new pathogenic mechanisms responsible for hypercholesterolaemia and associated with coronary artery disease. It may also lead to the development of new cholesterol-lowering agents.

In conclusion our results obtained in a sample of 33 ADH families show that

- 1) mutations in the *LDLR* gene are the most frequent defects;
- 2) molecular defects associated with the disease are located within at least four loci;
- 3) together the unknown loci, have a greater contribution to the phenotype than that of the *APOB* gene.

These results obtained in a small sample of French families await confirmation in other populations and better assessment in larger samples, but do not preclude the identification of the gene involved in the three French 'non-LDLR / non-APOB' ADH families reported.

#### Acknowledgements

The authors wish to thank Maria Martinez for numerous fruitful and helpful discussions. This work was supported by INSERM, Faculté de Médecine Necker, Université Paris V, PROGRES-INSERM, ARCOL, and Parke-Davis.

#### References

- 1 Goldstein J, Brown M: Familial Hypercholesterolemia. In: Scriver C, Beaudet A, Sly W, Valle D (eds): *The Metabolic Basis of Inherited Disease*, 6th edn. McGraw-Hill: New York, 1989, pp 1215-1250.
- 2 Yamamoto T, Davis CG, Brown MS *et al*: The human LDL receptor: a cysteine-rich protein with multiple Alu sequences in its mRNA. *Cell* 1984; **39**: 27-38.
- 3 Lindgren V, Luskey KL, Russell DW, Francke U: Human genes involved in cholesterol metabolism: chromosomal mapping of the loci for the low density lipoprotein receptor and 3-hydroxy-3-methylglutaryl-coenzyme A reductase with cDNA probes. *Proc Natl Acad Sci USA* 1985; **82**: 8567-8571.
- 4 Varret M, Rabès JP, Thiar R *et al*: LDLR Database, 2nd edn. New additions to the database and the software, and results of the first molecular analysis *Nucleic Acids Res* 1998; **26**: 248-252.
- 5 McKusick V: Mendelian Inheritance in Man. John Hopkins University Press: Baltimore, 1988.
- 6 Hobbs HH, Brown MS, Goldstein JL: Molecular genetics of the LDL receptor gene in familial hypercholesterolemia. *Hum Mutat* 1992; **1**: 445-466.
- 7 Sun XM, Patel DD, Knight BL, Soutar AK: Comparison of the genetic defect with LDL-receptor activity in cultured cells from patients with a clinical diagnosis of heterozygous familial hypercholesterolemia. The Familial Hypercholesterolaemia Regression Study Group. *Arterioscler Thromb Vasc Biol* 1997; **17**: 3092-3101.
- 8 Vega GL, Grundy SM: *In vivo* evidence for reduced binding of low density lipoproteins to receptors as a cause of primary moderate hypercholesterolemia. *J Clin Invest* 1986; **78**: 1410-1414.
- 9 Innerarity TL, Weisgraber KH, Arnold KS *et al*: Familial defective apolipoprotein B-100: low density lipoproteins with abnormal receptor binding. *Proc Natl Acad Sci USA* 1987; **84**: 6919-6923.
- 10 Soria LF, Ludwig EH, Clarke HR, Vega GL, Grundy SM, McCarthy BJ: Association between a specific apolipoprotein B mutation and familial defective apolipoprotein B-100. *Proc Natl Acad Sci USA* 1989; **86**: 587-591.
- 11 Ludwig EH, McCarthy BJ: Haplotype analysis of the human apolipoprotein B mutation associated with familial defective apolipoprotein B100. *Am J Hum Genet* 1990; **47**: 712-720.
- 12 Loux N, Saint-Jore B, Collod G *et al*: Identification of the haplotype associated with the APOB-3500 mutation in a French hypercholesterolemic subject: further support for a unique European ancestral mutation. *Hum Mutat* 1993; **2**: 145-147.
- 13 Gaffney D, Reid JM, Cameron IM *et al*: Independent mutations at codon 3500 of the apolipoprotein B gene are associated with hyperlipidemia. *Arterioscler Thromb Vasc Biol* 1995; **15**: 1025-1029.
- 14 Pullinger CR, Hennessy LK, Chatterton JE *et al*: Familial ligand-defective apolipoprotein B. Identification of a new mutation that decreases LDL receptor binding affinity. *J Clin Invest* 1995; **95**: 1225-1234.
- 15 Ludwig EH, Hopkins PN, Allen A *et al*: Association of genetic variations in apolipoprotein B with hypercholesterolemia, coronary artery disease, and receptor binding of low density lipoproteins. *J Lipid Res* 1997; **38**: 1361-1373.
- 16 Tybjærg-Hansen A, Steffensen R, Meinertz H, Schnohr P, Nordestgaard BG: Association of mutations in the apolipoprotein B gene with hypercholesterolemia and the risk of ischemic heart disease. *N Engl J Med* 1998; **338**: 1577-1584.
- 17 Varret M, Rabès JP, Saint-Jore B *et al*: A third major locus for autosomal dominant hypercholesterolemia maps to 1p34.1-p32. *Am J Hum Genet* 1999; **64**: 1378-1387.
- 18 Goldstein JL, Schrott HG, Hazzard WR, Bierman EL, Motulsky AG: Hyperlipidemia in coronary heart disease. II. Genetic analysis of lipid levels in 176 families and delineation of a new inherited disorder, combined hyperlipidemia. *J Clin Invest* 1973; **52**: 1544-1568.
- 19 Innerarity TL, Mahley RW, Weisgraber KH *et al*: Familial defective apolipoprotein B-100: a mutation of apolipoprotein B that causes hypercholesterolemia. *J Lipid Res* 1990; **31**: 1337-1349.
- 20 Rauh G, Keller C, Schuster H, Wolfram G, Zollner N: Familial defective apolipoprotein B-100: a common cause of primary hypercholesterolemia. *Clin Invest* 1992; **70**: 77-84.
- 21 Morganroth J, Levy RI, McMahon AE, Gotto AM Jr: Pseudohomozygous type II hyperlipoproteinemia. *J Pediatr* 1974; **85**: 639-643.
- 22 Zuliani G, Arca M, Signore A *et al*: Characterization of a new form of inherited hypercholesterolemia: familial recessive hypercholesterolemia. *Arterioscler Thromb Vasc Biol* 1999; **19**: 802-809.
- 23 Hobbs HH, Leitersdorf E, Leffert CC, Cryer DR, Brown MS, Goldstein JL: Evidence for a dominant gene that suppresses hypercholesterolemia in a family with defective low density lipoprotein receptors. *J Clin Invest* 1989; **84**: 656-664.
- 24 Nissen H, Hansen PS, Faergeman O, Horder M: Mutation screening of the codon 3500 region of the apolipoprotein B gene by denaturing gradient-gel electrophoresis. *Clin Chem* 1995; **41**: 419-423.
- 25 Miserez AR, Schuster H, Chiodetti N, Keller U: Polymorphic haplotypes and recombination rates at the LDL receptor gene locus in subjects with and without familial hypercholesterolemia who are from different populations. *Am J Hum Genet* 1993; **52**: 808-826.
- 26 Haddad L, Day IN, Hunt S, Williams RR, Humphries SE, Hopkins PN: Evidence for a third genetic locus causing familial hypercholesterolemia. A non-LDLR, non-APOB kindred. *J Lipid Res* 1999; **40**: 1113-1122.
- 27 Lusis AJ: Genetic factors affecting blood lipoproteins: the candidate gene approach. *J Lipid Res* 1988; **29**: 397-429.
- 28 Steinmetz J: Le Cholestérol total. In: Siest G, Henny J, Schiele F (eds): *Références en Biologie Clinique*. Elsevier: Paris, 1990, pp 190-209.
- 29 Leitersdorf E, Tobin EJ, Davignon J, Hobbs HH: Common low-density lipoprotein receptor mutations in the French Canadian population. *J Clin Invest* 1990; **85**: 1014-1023.

- 30 Loux N, Saint-Jore B, Colod G *et al*: Screening for new mutations in the LDL receptor gene in seven French familial hypercholesterolemia families by the single strand conformation polymorphism method. *Hum Mutat* 1992; **1**: 325-332.
- 31 Orita M, Sekiya T, Hayashi K: DNA sequence polymorphisms in Alu repeats. *Genomics* 1990; **8**: 271-278.
- 32 Ashworth LK, Batzer MA, Brandriff B *et al*: An integrated metric physical map of human chromosome 19. *Nat Genet* 1995; **11**: 422-427.
- 33 Zuliana G, Hobbs HH: Dinucleotide repeat polymorphism at the 3' end of the LDL receptor gene. *Nucleic Acids Res* 1990; **18**: 4300.
- 34 Hazan J, Dubay C, Pankowiak MP, Becuwe N, Weissenbach J: A genetic linkage map of human chromosome 20 composed entirely of microsatellite markers. *Genomics* 1992; **12**: 183-189.
- 35 Boerwinkle E, Xiong WJ, Fourest E, Chan L: Rapid typing of tandemly repeated hypervariable loci by the polymerase chain reaction: application to the apolipoprotein B 3' hypervariable region. *Proc Natl Acad Sci USA* 1989; **86**: 212-216.
- 36 Boerwinkle E, Chan L: A three codon insertion/deletion polymorphism in the signal peptide region of the human apolipoprotein B (APOB) gene directly typed by the polymerase chain reaction. *Nucleic Acids Res* 1989; **17**: 4003.
- 37 Rabès JP, Varret M, Saint-Jore B *et al*: Familial ligand-defective apolipoprotein B-100: simultaneous detection of the ARG3500→GLN and ARG3531→CYS mutations in a French population. *Hum Mutat* 1997; **10**: 160-163.
- 38 Lathrop GM, Lalouel JM, Julier C, Ott J: Strategies for multilocus linkage analysis in humans. *Proc Natl Acad Sci USA* 1984; **81**: 3443-3446.
- 39 Smith C: Testing for heterogeneity of recombination values in human genetics. *Am J Hum Genet* 1963; **27**: 175-182.
- 40 Ott J: *Analysis of Human Genetic Linkage*. Johns Hopkins University Press: Baltimore, 1991.
- 41 Williams RR, Hunt SC, Schumacher MC *et al*: Diagnosing heterozygous familial hypercholesterolemia using new practical criteria validated by molecular genetics. *Am J Cardiol* 1993; **72**: 171-176.
- 42 Tybjærg-Hansen A, Gallager J, Vincent J *et al*: Familial defective apolipoprotein B-100: detection in the United Kingdom and Scandinavia, and clinical characteristics of ten cases. *Atherosclerosis* 1990; **80**: 235-242.
- 43 Talmud P, Tybjærg-Hansen A, Bhatnagar D *et al*: Rapid screening for specific mutations in patients with a clinical diagnosis of familial hypercholesterolaemia. *Atherosclerosis* 1991; **89**: 137-141.
- 44 Miserez AR, Laager R, Chiodetti N, Keller U: High prevalence of familial defective apolipoprotein B-100 in Switzerland. *J Lipid Res* 1994; **35**: 574-583.